

FireBird® Pro / FireBird® Pro GE

- | | | |
|--|---|---|
| DE Akku-Blindnietmutternsetzgerät
Betriebsanleitung | DK Ledningsfrit blindnietmøtrik-
isætningsapparat
Brugsanvisning | GR Συσκευή τοποθέτησης παξιμαδιών τυφλών
πρισινιών με επαναφορτιζόμενη μπαταρία
Οδηγίες χρήσης με κατάλογο ανταλλακτικών |
| GB Battery powered blind rivet nut setting
tool
Operating instructions | SE Batteridrivnen blindnietmutterpistol
Bruksanvisning | HU Akkumulátoros vakszegecs anya beültető készülék
Üzemeltetési útmutató alkatrészlistával |
| FR Outil de pose d'écrous aveugles à batterie
Mode d'emploi | NO Oppladbart batteri for pistol til setting
av blindnagle Muttere
Brukerhåndbok | PL Nitownica akumulatorowa do nitonakrętek
Instrukcja obsługi z wykazem części zamiennych |
| ES Remachadora a batería de tuercas
remachables
Manual de instrucciones | FI Akkukäyttöinen niittimutterityökalu
Käyttöohje | CN 充电式铆螺母枪
操作说明书及备件目录 |
| IT Inseritore di inserti filettati a batteria
Istruzioni per l'uso | PT Rebitador sem fios
Instruções de serviço | RU Аккумуляторный заклепочник для заклепок-гаек
Инструкция по эксплуатации и ведомость запасных
частей |
| NL Accu-blindklinkmoerpistol
Handleiding | CZ Akumulátorové nýtovací nářadí pro
nýtovací matice
Návod k obsluze | |



GESIPA Blindniettechnik GmbH
Nordendstraße 13-39
64546 Mörfelden-Walldorf
Germany

T +49 (0) 6105 962 0
F +49 (0) 6105 962 287
info@gesipa.com
www.gesipa.com

GESIPA®

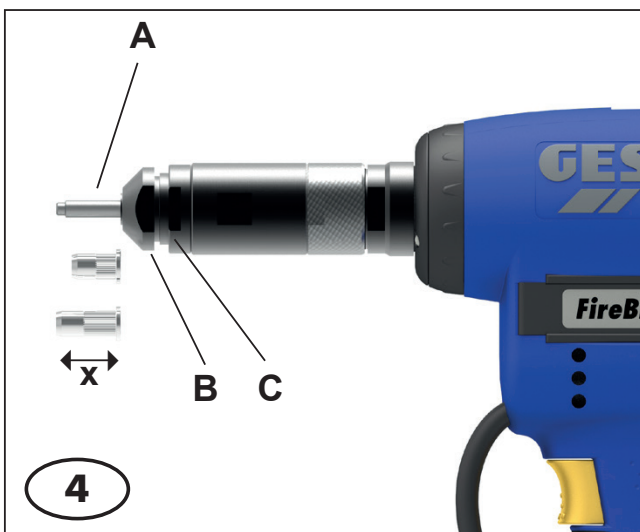
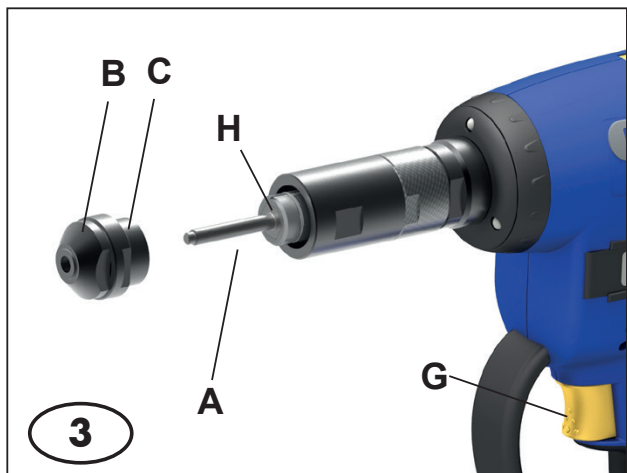
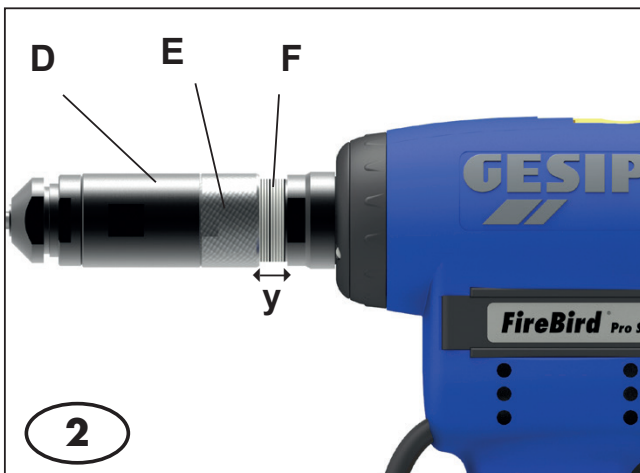

DE

Pos.	Bezeichnung	Abb.
A	Gewindedorn	1; 3; 4
B	Mundstück	1; 3; 4
C	Kontermutter	1; 3; 4
D	Aufhänger	2
E	Sicherungsschraube	2
F	Abdeckung	2
G	Display	1; 3
H	Beleuchtung	3
I	Schalter	
J	Schieber	
x	Gewindedornlänge	4

GB

Item	Description	Fig.
A	Threaded mandrel	1; 3; 4
B	Nosepiece	1; 3; 4
C	Lock nut	1; 3; 4
D	Hanger	2
E	Locking screw	2
F	Cover	2
G	Display	1; 3
H	Lighting	3
I	Switch	
J	Slide	
x	Threaded mandrel length	4

FR

Pos.	Désignation	Fig.
A	Mandrin fileté	1; 3; 4
B	Embouchure	1; 3; 4
C	Contre-écrou	1; 3; 4
D	Écrou de réglage	2
E	Vis de sécurité	2
F	Couvercle	2
G	Écran	1; 3
H	Éclairage	3
I	Interrupteur	
J	Piston de contrôle	
x	Longueur du mandrin fileté	4

ES

Pos.	Denominación	Fig.
A	Vástago	1; 3; 4
B	Boquilla	1; 3; 4
C	Contratuerca	1; 3; 4
D	Anillo de suspensión	2
E	Tornillo de retención	2
F	Tapa	2
G	Pantalla	1, 3
H	Iluminación	3
I	Interruptor	
J	Pasador	
x	Longitud del vástago	4

IT

Pos.	Designazione	Fig.
A	Mandriño filettato	1; 3; 4
B	Bocchello	1; 3; 4
C	Controdado	1; 3; 4
D	Gancio di sospensione	2
E	Vite di sicurezza	2
F	Protezione	2
G	Display	1, 3
H	Illuminazione	3
I	Interruttore	
J	Spintore	
x	Lunghezza mandriño filettato	4

NL

Pos.	Naam	Afb.
A	Draadspindel	1; 3; 4
B	Mondstuk	1; 3; 4
C	Contraoer	1; 3; 4
D	Ophangoog	2
E	Borgschroef	2
F	Afdekking	2
G	Display	1, 3
H	Verlichting	3
I	Schakelaar	
J	Schuif	
x	Draadspindellengte	4

Table of Contents

1.	FireBird® Pro GE / FireBird® Pro GE blind rivet nut setting tool.....	22
1.1	Working range	22
1.2	Equipment / accessories	22
1.3	Technical data	23
1.4	Safety instructions	23
1.5	Start-up.....	24
1.6	Lighting	24
1.7	Maintenance	24
1.8	Storage	24
2.	Functional principle.....	25
2.1	Replacement of the threaded mandrel (Fig. 3).....	25
2.2	Adjusting the threaded mandrel length “X”	25
2.3	Adjusting the setting force	25
2.4	Saving and loading the setting force	27
2.5	Screwing on the blind rivet nut	27
2.6	Manual unscrewing of the blind rivet nut	28
2.7	Setting a blind rivet nut.....	28
3.	Troubleshooting	29
3.1	Blind rivet nut is not screwed on.....	29
3.2	Blind rivet nut is not unscrewed.....	29
3.3	Set blind rivet nut is not completely set	29
3.4	LED lights flashing.....	29
3.5	Repairs	30
4.	Warranty	31
5.	Declaration of conformity.....	31

1. FireBird® Pro GE / FireBird® Pro GE blind rivet nut setting tool

1.1 Working range

	M3	M4	M5	M6	M8	M10	M12
Alu	FB FB GE	FB FB GE	FB FB GE	FB FB GE	FB FB GE	FB GE	FB GE
Steel	FB FB GE	FB FB GE	FB FB GE	FB FB GE	FB FB GE	FB GE	FB GE
Stainless steel	FB FB GE	FB FB GE	FB FB GE	FB FB GE	FB GE	FB GE	-

Note: Depending on the blind rivet nut manufacturer, ambient temperature and battery type used, the working range may be limited.

FB = FireBird® Pro

FB GE = FireBird® Pro Gold Edition

1.2 Equipment / accessories

Nosepiece / threaded mandrels	
for FB Pro	M6 in working position M4, M5 in accessory magazine
for FB Pro GE	M6 in working position M8, M10 in accessory magazine
Hanger	Concealed in housing
Quick charger	110 V (USA) or 230 V (EU) / 50-60 Hz
Quick-change battery	18.0 V / 2.0 Ah
Scope of delivery	Hexagon screwdriver WAF 4 2x double open-ended spanner WAF 24/27 Quick-setting guide Article No. 1699983 Setting force guide Article No. 1699984 1x locking screw for HMI cover Operating instructions

1.3 Technical data

Weight	approx. 2.4 kg (incl. 2.0 Ah rechargeable battery and nosepiece/mandrel magazine)
Max. setting stroke	10 mm
Drive	Brushless DC motor
Tensile strength	15 kN for FB Pro 20 kN for FB Pro GE
Noise emissions	LPA 76.5 dB (A), measurement uncertainty K = 3 dB
Vibration	< 2.5 m/s ² , measurement uncertainty K = 1.5 m/s ²

1.4 Safety instructions

Caution: The tool is not suitable for use in an ATEX zone.

The following safety rules must be observed to ensure adequate protection against electric shock, injuries or fire hazards:

- The blind rivet nut setting tool is intended solely for the purpose of setting blind rivet nuts and blind rivet studs!
- Wear safety goggles at all times when working with the blind rivet nut setting tool!
- Do not use the tool without material!
- Do not overload the blind rivet nut setting tool; work within the specified performance range.
- Never use or store the blind rivet nut setting tool in a damp/wet environment or in the vicinity of flammable liquids and gases (risk of explosion!) and protect from frost during storage.
- Ensure that the battery is properly secured in the grip.
- Always remove the battery when the blind rivet nut setting tool is not in use and during maintenance work.
- The battery may only be charged in the temperature range between 0°C and +50°C.
- Do not use the blind rivet nut setting tool as a hammer.
- Keep device, battery packs and charger away from children.
- Depending on the working arrangements, personal protective equipment (PPE) is recommended (e.g. protective clothing, gloves, safety helmet, non-slip shoes, hearing protection or fall protection).
- The air inlets for the motor must not be obstructed; do not insert any objects into them.
- When setting the blind rivet nut setting tool down, make sure that it cannot fall down.
- Use only genuine spare parts for repair.
- Repairs must be carried out only by skilled personnel. In case of doubt, send in the blind rivet nut setting tool to the manufacturer.

1.5 Start-up



Important!

Fully charge the battery before using for the first time!

- Insert fully charged battery into the blind rivet nut setting tool in the correct position.
- Use a threaded mandrel and nosepiece size matching the size of the blind rivet nut.
- The blind rivet nut setting tool can be used either with or without accessory magazine.

1.6 Lighting

The blind rivet nut setting tool is equipped with a workplace light comprising 3 LEDs to illuminate the work space; the light can be switched on by turning the black ring behind the LEDs. There are 3 settings indicated by an arrow moulded into the housing:

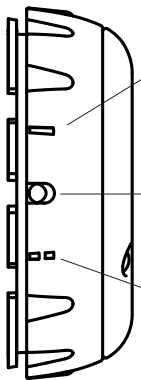

— Continuous light/torch function:

The light is switched on after a riveting operation and stays on for approx. 10 minutes. The LEDs then turn off automatically.

● Zero position::

Lights switched off.

-- Work light:

The light is switched on at the start of the riveting operation. The LEDs stay on for about 10 seconds and then switch off automatically.

1.7 Maintenance

Maintenance of the blind rivet nut setting tool is limited to the replacement of worn threaded mandrels and nosepieces, as necessary (see section 2.1 for replacement of the threaded mandrels).

Regular maintenance will extend the service life of your high-quality GESIPA® tools which should be serviced at least every 2 years by an authorised workshop or by GESIPA® Service. We recommend servicing of tools subject to intensive use at shorter intervals.

1.8 Storage

Store the blind rivet nut setting tool in a dry place where there is no danger of frost.

2. Functional principle

2.1 Replacement of the threaded mandrel (Fig. 3)

- Remove the battery from the tool.
- Loosen lock nut C using a double open-ended spanner (WAF 24/27).
- Unscrew nosepiece B.
- Push back slide J as far as it will go.
- Unscrew threaded mandrel A.
- Align the appropriate threaded mandrel A with the hexagonal surface in slide J.
- Screw on a nosepiece B matching the thread size and secure with lock nut C.

2.2 Adjusting the threaded mandrel length “X”

- Loosen lock nut C.
- Adjust the threaded mandrel length “X” to the nut length by turning nosepiece B (Figure 4).
- Fully utilise the thread depth of closed blind rivet nuts (Figure 4).
- Hold nosepiece B with lock nut lock C using a double open-ended spanner (WAF 24/27) to prevent it from turning.

2.3 Adjusting the setting force

The setting force to be set depends on the blind rivet nut size and blind rivet nut material, and on the materials to be riveted (material, hole diameter, material thickness).

The setting force is adjusted as follows:

1. Select the setting value from the quick setting guide
2. Set the selected setting value on the display
3. Carry out a few setting trials and adjust the setting value, if necessary

1. Select the setting value from the quick setting guide

The appropriate numerical value can be selected in the quick setting guide, depending on the blind rivet nut size and blind rivet nut material.

(e.g. M5 - steel ⇒ Guide value for the setting force 45)

These guide values have been determined using GESIPA® blind rivet nuts.

Excerpt from the quick setting guide:

	M3	M4	M5	M6	M8	M10	M12
Alu	03	10	20	40	45	50	90
Steel	10	40	45	60	75	90	98
Stainless steel	15	30	50	85	95	98	-

2. Set the selected setting value on the display

Wake up the tool by briefly pressing switch I. Important! Threaded mandrel A turns when the switch is pressed! Hold the tool only at the handle.

Remove cover F, then set the selected value on the display G by pressing the plus or minus buttons. Pressing the plus button increases the numerical value. Pressing the minus button decreases the numerical value. If a button is held down for longer than one second, the numerical value changes in increments of 10.

The setting force of the riveting tool is increased by increasing the numerical value on display G; the setting force is reduced by reducing the numerical value.

3. Carry out a few setting trial and adjust the setting value, if necessary

Important! As the setting behaviour can vary, depending on the blind rivet nut type, manufacturer or material thickness, a setting trial is recommended before riveting the selected part. This should - if possible - be carried out on the original part.

Carry out the setting trial as described in section 2.7, then assess the setting result:

Blind rivet nut not completely set

- Blind rivet nut not sufficiently deformed or closing head not completely formed
- Increase the setting value in small increments

Blind rivet nut set with excessive force

- Thread deformed or stripped (automatic unscrewing no longer possible, see section 3.2)
- Threaded mandrel bent or broken
- Reduce the setting value Blind rivet

Nut correctly set

- Closing head completely formed, thread not damaged

After adjusting the setting value, carry out a further setting trial and assess the setting result.

Important! If the correct setting value is not known or if in doubt, always start with lower values in order to avoid damaging the tool!

2.4 Saving and loading the setting force

The FireBird® Pro (GE) is able to save the set force value to its integrated program memory and to load it again wherever necessary.

Save the numerical values as follows:

- Determine and set the numerical value to be programmed (see section 2.3).
- Holding the S button down for longer than one second (> 1 sec.) calls up the program memory (initial value P0) in order to save a set numerical value.
- A program memory location from P0 to P9 can be selected by pressing the plus or minus button.
- Press the S button again (> 1 sec.) to save the numerical value and show it on the display once more.

Previously saved numerical values can be called up as follows:

- Pressing the plus and minus buttons are pressed at the same time for more than two seconds (> 2 sec.) calls up the program memory.
- A previously saved numerical value between P0 and P9 can be selected by pressing the plus or minus button.
- Holding the S button pressed again (> 1 sec.) loads the selected program and the corresponding numerical value is displayed.

The load or save sequence can be cancelled at any time by pressing the plus and minus buttons at the same time (> 2 sec.).

2.5 Screwing on the blind rivet nut

- Place the blind rivet nut onto threaded mandrel A straight.
- We recommend that the blind rivet nut is screwed on by hand by approx. ½ turn to simplify threading in of threaded mandrel A.
- Start the screw-on sequence by pressing switch I.
- Hold switch I pressed until the screw-on sequence stops automatically. While doing this, hold the blind rivet nut secure to prevent twisting during the entire screw-on sequence. The blind rivet nut must be correctly positioned on nosepiece B after the screw-on sequence. Otherwise, correct the setting of the threaded mandrel length (see Section 2.2).

Caution: If the switch is released prematurely, the nut will be unscrewed again!

2.6 Manual unscrewing of the blind rivet nut

Manual unscrewing of a blind rivet nut may be necessary if:

- The blind rivet nut was not screwed on straight before the setting operation, or the thread of the blind rivet nut or threaded mandrel 1 is defective;
 - The thread is deformed after the setting operation and the tool does not unscrew automatically (setting force selected too high, wrong setting!) and cuts out due to overloading. This is signalled as error message “E3” on the display and by rapid flashing of the light ring.
- Remove the battery. Then unscrew the threaded mandrel by hand. To do this, insert the hexagon screwdriver WAF 4 into the hexagon socket of the tool (see Figure 5), possibly after removing the accessory magazine (Figure 5), if necessary. Carefully loosen threaded mandrel A by screwing in anti-clockwise direction. After unscrewing the deformed nut, insert the battery into the tool again and remove the hexagon screwdriver. Press and release switch I to bring the tool back to Home position in a slow reference run. The last numerical value set is shown on the display. Caution: Set the correct (lower!) numerical value as described in section 2.3.

2.7 Setting a blind rivet nut

- Insert the correctly fitted nut into the hole of the workpiece as far as it will go using the blind rivet nut setting tool.
- Start the setting operation by pressing switch I. The setting operation runs until the set setting force is reached before the set blind rivet nut is unscrewed again automatically.
- Important!

Incorrect setting operation: Error message E1

If the set numerical value is not reached during the setting operation, the setting operation stops, the tool unscrews the nut and automatically returns to Home position. Error message “E1” appears on the display G. The error is additionally signalled by rapid flashing of the light ring H and rapid beeps. Acknowledge the error by pressing the S button (> 1 sec). Only then can the tool be used again. rS (reSet) is shown on the display G. In this mode, the incorrectly set blind rivet nut can be reset at reduced speed. To do this, screw on the nut already set again (see section 2.5) and press switch I again. After one rS setting operation, the last numerical value set appears on the display G again. If the blind rivet nut is not reset, quit rS mode by pressing the S button (>1 sec).

- Important!
Resetting of one or more blind rivet nuts: If one or more blind rivet nuts have been set with a numerical value that is too low, it is possible to reset these blind rivet nuts in rr mode (reWork). To do this, select the correct numerical value for the setting force (see section 2.3). Then hold the S button pressed until the program memory P0 - P9 has been skipped and rr appears on the display G. All incorrectly set nuts can then be reset with the corrected numerical value. Press the S button again to bring the tool back to normal mode.

3. Troubleshooting

3.1 Blind rivet nut is not screwed on

Possible causes	Corrective measures
Nut thread defective	Use new nut
Threaded mandrel defective	Replace threaded mandrel (section 2.1)
Nut does not rest against nose-piece	Threaded mandrel length x incorrect; adapt to nut length (section 2.2)
Nut unscrews again	Hold switch I pressed until the tool comes to a standstill (section 2.5)
Battery is discharged Error indicated on the display E4	Charge the battery

3.2 Blind rivet nut is not unscrewed

Possible causes	Corrective measures
Nut thread deformed due to excessive setting force Error indicated on the display: E3	Reduce the setting force (section 2.3); remove using hexagon screwdriver (section 2.6; see Fig. 5)
Nut thread completely destroyed. Error indicated on the display E1	Reduce the numerical value (section 2.3) Acknowledge the error (section 2.4)

3.3 Set blind rivet nut is not completely set

Possible causes	Corrective measures
Numerical value is set too low	Set the correct numerical value (section 2.3)
Set numerical value not reached or setting stroke too short. Error indicated on the display E1	Reset the blind rivet nut in ReSet mode (section 2.7)
Overload during drawing operation. Error indicated on the display E2	Observe the working range (section 1.1)
Battery is discharged Error indicated on the display E4	Charge the battery

3.4 LED lights flashing

Possible causes	Corrective measures
Battery is discharged	Charge the battery
Overload during extraction process (slow flashing)	Observe the working range (section 1.1)
Nut cannot be unscrewed. Nut thread deformed/destroyed due to excessive setting stroke (rapid flashing)	Remove nut using hexagon screwdriver (section 5; see figure 5); Reduce setting stroke (section 2.3)

3 beeps and flashing LED lights for 10 seconds:

The battery needs to be changed soon (about 20% battery charge remaining).

6 beeps and flashing LED lights for 10 seconds after every setting sequence: Change the battery after a few more riveting sequences to guarantee safe and secure riveting sequences (approx. 10% battery remaining).

9 beeps and flashing LED lights for 10 seconds: The next riveting sequence cannot be reliably carried out. The tool is switched off. Change the battery.

3.5 Repairs

Repairs under warranty are carried out by the manufacturer. Repairs outside the warranty period should only be carried out by skilled technical personnel. Failure to observe the assembly and setting instructions and operation by non-skilled personnel may result in serious damage to the blind rivet nut setting tool. In case of doubt, always send in the blind rivet nut setting tool to the supplier or to GESIPA®.

Important! In the case of repairs not carried out by the manufacturer or where special accessories (e.g. extension units, angle heads) are used, it is mandatory to carry out a manual reference run before using the tool again!

1. Ensure that the tool is ready for operation and that all required attachments are correctly mounted on it, then insert the battery.
2. Turn LED ring to • zero position.
3. Press and hold* the trigger button: the tool will move to the rear end position (riveting tools) or drill briefly (blind riveting tools) and then stop.
4. Turn LED ring to — Continuous light, without releasing the trigger button.
5. Hold the trigger pressed for a further 10 seconds until the tool beeps 3x.
6. The trigger button can now be released: the old reference values have been deleted.
7. Pressing the trigger button* again starts the reference run; the tool will move forward and back several times, flashing all the time.

*On tools with a spring-loaded trigger system, this must be pressed to release the tool.

After this reference run, start operation as described in section 1.5. Starting operation after a repair without carrying out a manual reference run can result in serious damage to the blind rivet nut setting tool.

You can find the current spare parts list for your tool online at www.gesipa.com.

4. Warranty

The latest version of the warranty conditions that can be viewed under the following link: www.gesipa.com/agb shall apply.

5. Declaration of conformity

We hereby declare that the tool described below, due to its design and construction, and in the version as placed by us on the market, complies with the relevant fundamental safety and health requirements of the EC directives. Any modification of the device not approved by us will void this declaration. The safety instructions contained in the product documentation supplied must be observed. This document must be available at all times.

FireBird® Pro

FireBird® Pro Gold Edition

- DIN EN ISO 12100:2011
- DIN EN ISO 82079-1:2013
- DIN EN 55014-1:2016
- DIN EN 55014-2:2016
- DIN EN 61000-4-2:2009
- DIN EN 61000-4-3:2011
- DIN EN 62233:2008+
- EN 60335-1:2012
- EN 60335-2-29:2010
- DIN EN 62133:2013
- DIN EN 62841-1:2016-07
- 2012/19/EU
- 2011/65/EU
- 2006/42/EG
- 2014/35/EU
- 2014/30/EU

Authorised documentation officer:
GESIPA Blindniettechnik GmbH
Nordendstraße 13-39
64546 Mörfelden-Walldorf,
Germany



pp. Dipl.-Ing. Stefan Petsch
Head of Operations Tools Member of
Division Management

ⒹⒺ Ihr Fachhändler

ⒹⒶ Deres forhandler

ⒹⒷ Το ειδικό σας κατάστημα

ⒹⒸ Your dealer

ⒹⒺ Din återförsäljare

ⒹⒸ Az Ön szaküzlete

ⒹⒺ Cachet du revendeur

ⒹⒸ Deres forhandler

ⒹⒸ Dystrybutor

ⒹⒺ Vendedor autorizado

ⒹⒸ Jälleenmyyjä

ⒹⒸ 经销商

ⒹⒸ Rivenditore autorizzato

ⒹⒸ O vosso distribuidor

ⒹⒸ Ваш дилер

ⒹⒸ Uw vakhandelaar

ⒹⒸ Váš prodejce

