

# RIVTEC®

## Huck® 256

### Air Tool for Structural Rivets and Lockbolts

The Model 256 tool is designed for high-speed production applications, able to install up to 20 fasteners per minute. Slightly more swaging power than the Model 255 allows the 256 to install up to 3/8" steel Magna-Grip fasteners. The tool provides optimum stroke for one-cycle installations, and features an concentric (inline) pull piston and new front gland design, allowing for easy piston removal. The 256 is factory-tested for 2000 cycles, ensuring the tool's reliability, and plated piston rods extend seal life, adding to its durability.

### Setting Capacity

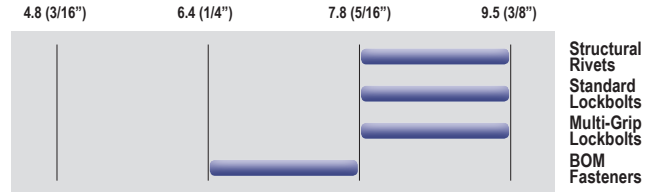

Quick and easy to change nose assemblies for various applications



\* Nose assemblies sold separately

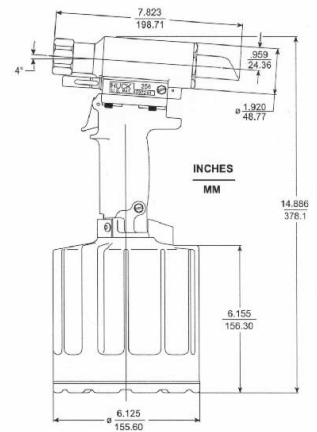

Specifications		Package Accessories
Product Code:	TA-246	Nosepiece Spanner
Weight:	5.03 kg	Spent Mandrel Guard
Length:	213 mm	17/19mm & 19/21mm Spanner
Operating Air Pressure:	5 – 7 bar	10ml Syringe
Pulling Force:	44,420 N	5mm Allen Wrench
Stroke:	22.40 mm	Operator's Manual

\* Dimensions and specifications are subject to change without notice. Check your distributor for the latest data sheet.