

## Rivtec® F10B

### Pneumatic Rivet Nut Tool

The Rivtec® F10B is a lightweight cost-effective air rivet nut tool. The F10B is suitable for both production and project-based installations. It is supplied in a padded plastic carry case including two sets of nose assemblies.

### Setting Capacity

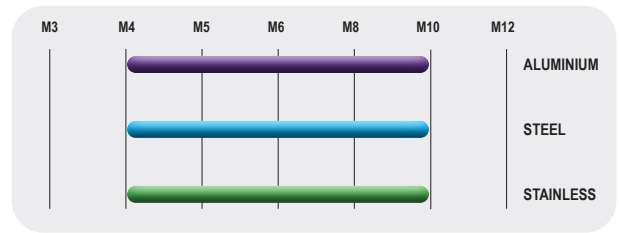

Industry standard socket head cap screw mandrel

Hydraulic Oil top up plug

Fast setting cycle with single trigger action for setting and spin-off

Spring Balance attachment for fatigue free operation

Quick and Easy Stroke Adjustment

Supplied in a lightweight padded carry case

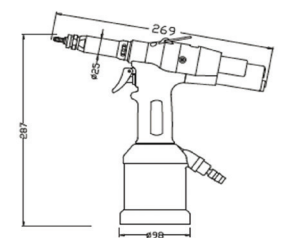

Specifications		Package Contents
Product Code:	RT-F10B	Mandrels and Nosepieces for M3, M4, M5, M6, M8 & M10
Weight:	2.10 kg	Spare Set of Mandrel M3 ~ M10
Length (without nose assembly):	269 mm	Lubricating Oil Bottle & Hydraulic Oil Bottle
Operating Air Pressure:	80 ~ 100 psi   5 ~ 7 bar	5ml Syringe, Maintenance Wrench: SW10/12, SW16/17
Pulling Force:	20 kN	Operating and Maintenance Manual
Stroke:	6.50 mm	Heavy Duty Plastic Carry Case