

TROUBLE SHOOTING

Indication	Cause	Solution
Tool installs rivet nut but will not reverse.	Usually because the stroke is too long and the insert thread has become distorted on the drive screw during installation.	Use the stroke adjustment tool in the slots above the trigger to dis-engage the tool from the insert.
Tool installs rivet-nut but strips thread on Mandrel or inside the rivet-nut.	The stroke is too long, or the thread on the drive screw is worn.	Adjust the stroke at the rear of the tool (-). Replace the drive screw.
Tool installs inserts erratically.	Usually because the air supply to the tool is varying in pressure.	A stable air supply is especially important for larger thread diameters. Check the trigger Pause-Time between setting the insert and reversing off. Is it sufficient?
Insert will not engage with the drive screw.	The drive screw thread is damaged or worn.	Replace the drive screw, it is a consumable and inexpensive to replace.
The air-motor runs slowly.	Most times the air motor needs lubrication.	Drip a small quantity of Motor-Lube-Oil into the airline.
The tool leaks oil.	Usually because of a loose hydraulic connection.	Return the tool to Rivtec workshop for maintenance.
The tool operation is inconsistent.	Usually because of poor or variable insert quality.	Use inserts reliable for wall thickness, hardness and plating quality.

Rivtec® Ltd

05/17

RIVTEC®

Rivtec Ltd
4 Hotunui Drive, Mt Wellington, Auckland New Zealand
Ph: 09 276 7021 | Fax: 09 276 7021
Email: sales@rivtec.co.nz
Web: www.rivtec.co.nz

RIVTEC®



RT-F10B Air Rivet Nut Tool M4 - M10

OPERATOR'S MANUAL

! IMPORTANT

Read this Operator's Manual carefully before operation.

Keep this manual for future reference.

INTRODUCTION

The F10B is a lightweight cost-effective air rivet nut tool. It is suitable for both production and project based installations. It is supplied in a padded carry case including two sets of nose assemblies.

SPECIFICATIONS

Weight	2.1kg	Width	98mm
Length	269mm	Stroke (Max).....	6.5mm
Height	289mm	Air Pressure	5-7 bar

PACKAGE ACCESSORIES

- F10B Rivet Nut Tool
- 2 x Nose assembly for M4 Rivet Nuts
- 2 x Nose assembly for M5 Rivet Nuts
- 2 x Nose assembly for M6 Rivet Nuts
- 2 x Nose assembly for M8 Rivet Nuts
- 2 x Nose assembly for M10 Rivet Nuts
- Padded plastic carry case
- Lubricating and Hydraulic Oil Bottle
- 5ml Syringe
- Maintenance Wrench SW10/12, SW16/17
- Operating Manual

Air Supply

This tool is designed to operate on clean, dry, regulated compressed air between 5-7 bar. It is preferable to include an air filter, pressure regulator and automatic oiler within 4.5 metres of the tool if possible. An air filter is recommended to remove contaminants and moisture that are contained in compressed air, filtering will significantly prolong the life of the tool.

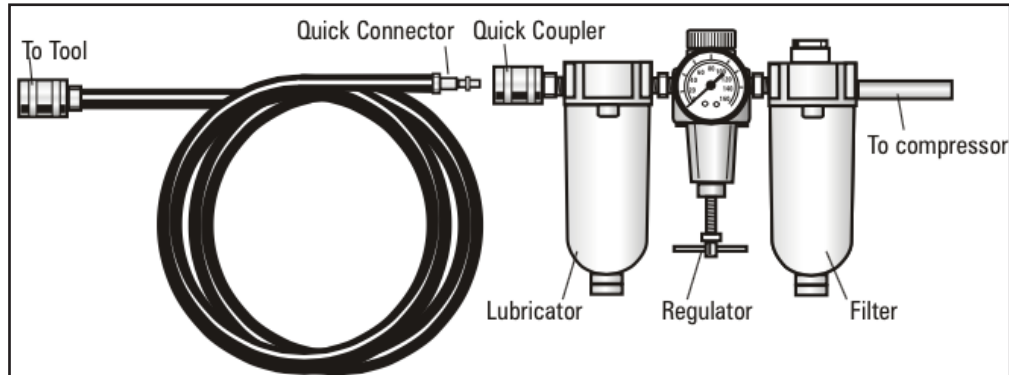

SAFETY INSTRUCTIONS



Caution! To ensure proper functioning and safe operation, read this Operator's Manual carefully before operating the RIVTEC® RT-F10B tool

- The F10B should be used exclusively to set rivet-nuts and rivet-studs.
- DO NOT overload the tool – work within the prescribed work capacity
- ALWAYS wear eye protection when working with the tool. Personal protection such as clothes, gloves, safety helmet, non-slipping shoes, ear protectors and protection against fall are highly recommended.
- This tool is NOT designed for use in explosive atmospheres.
- DO NOT use the tool as a hammer.
- Ensure the tool is not damaged before connecting to the air supply.
- Repair work must be carried out by trained personnel. In case of doubt, ALWAYS send back the tool to the supplier.
- ALWAYS disconnect the air supply when adjusting, servicing or removing any part of the tool.
- Keep fingers off the trigger when connecting the air supply or if the air supply fails.
- Keep fingers away from the front of the tool when connecting the air supply or setting rivets.
- DO NOT point the tool at anyone.
- DO NOT operate tool with the nose housing removed.
- DO NOT modify the tool in any way. Modifications could damage the tool.
- The operating pressure must not exceed 7 bar.
- Wash hands if exposed to hydraulic fluid or lubricant.
- Keep hair, fingers and loose clothing away from moving parts of the tool.

PREPARATION

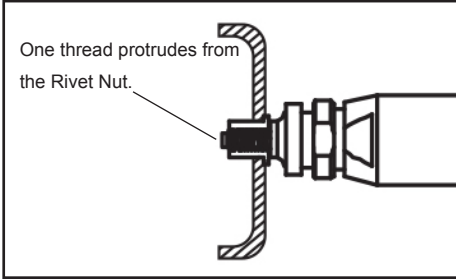

Adjust the Mandrel protrusion. Ideal protrusion is one thread length.

If the Mandrel protrudes too long or too short, adjust the anvil to the optimum position and lock the set nut.

Confirm Rivet Nut hole size and grip range to be correct?

OPERATION

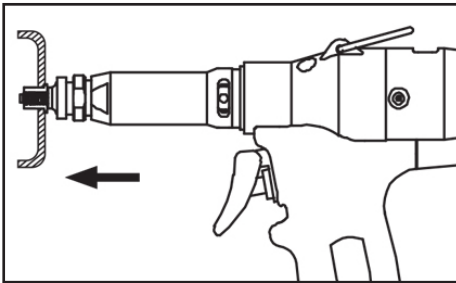

Action One

Start the Rivet-Nut onto the the drive screw sufficient to avoid cross-threading. Then push against the insert to activate the air motor.

The drive-screw is pressure sensitive, when pressed it will rotate clockwise.

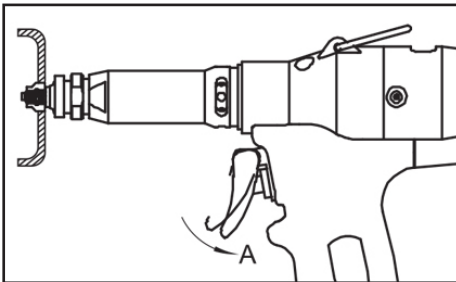

Action Two

Half-pull the trigger carefully and pause (The trigger has two action stages)

The first half pull activates the Pull-&-Set function of the tool.

The pause is to ensure that the insert is set and may take a 1/2 second.

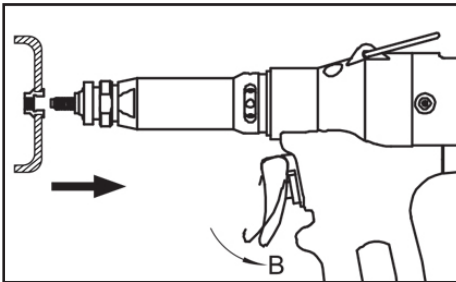

Action Three

Complete the Pull function of the Trigger (The second stage function of the trigger)

This activates the air motor to rotate anti-clockwise and reverse-off the installed Rivet Nut.

NB. Pulling the trigger too quickly will not give the tool sufficient time to set the Rivet Nut. If a reverse is required, fully pull the trigger without any pause.

NOSE REPLACEMENT PROCESS



Caution! Disconnect the air supply while servicing front end to avoid injury.

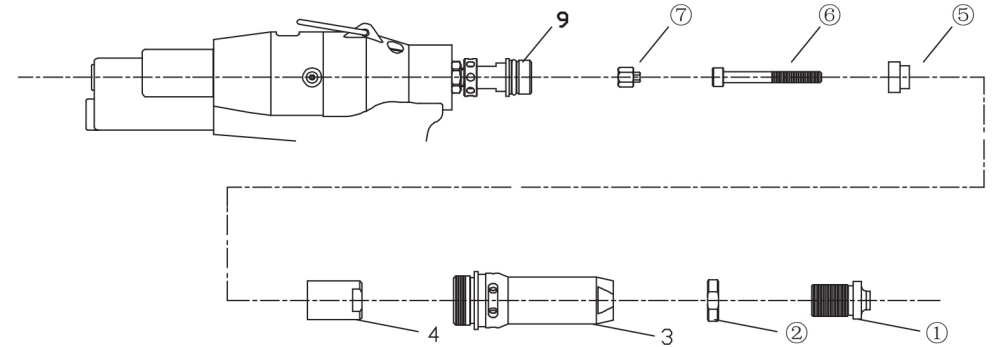

1. Disconnect the tool from the compressed air supply
2. Set the spanner onto lock nut (2) unscrew the nose piece (1) counter clockwise.
3. Unscrew the nose case off with the spanner.
4. Set the spindle (9) with the spanner, unscrew and remove the adaptor nut (4)
5. Change the drive shaft (7) mandrel (6) reducing the sleeve (5) accordingly.
6. Tighten the spindle (9) and the adaptor nut (4) clockwise with a spanner.
7. Screw on the nose casing (3) change and set the nose piece (1) in exact position according to the right mandrel protrusion, then lock nose piece lock nut with spanner.

STROKE ADJUSTMENT

Adjustment is very important to ensure optimum insert deformation.

If the stroke is too long... the Rivet Nut thread will be damaged.

If the stroke is too short... the Rivet Nut will likely rotate in the hole after install.

Always trial the set-up between changes of thread diameter or material thickness.

First replicate the hole diameter and material thickness.

Then install Rivet Nuts adjusting the tool progressively from the stroke-too-long thru to stroke-to-short.

The F10 is highly regarded for its ability to install inserts M3~M10.

Small thread diameters (M3-M4) are more difficult to install than larger threads.

DIAGRAM

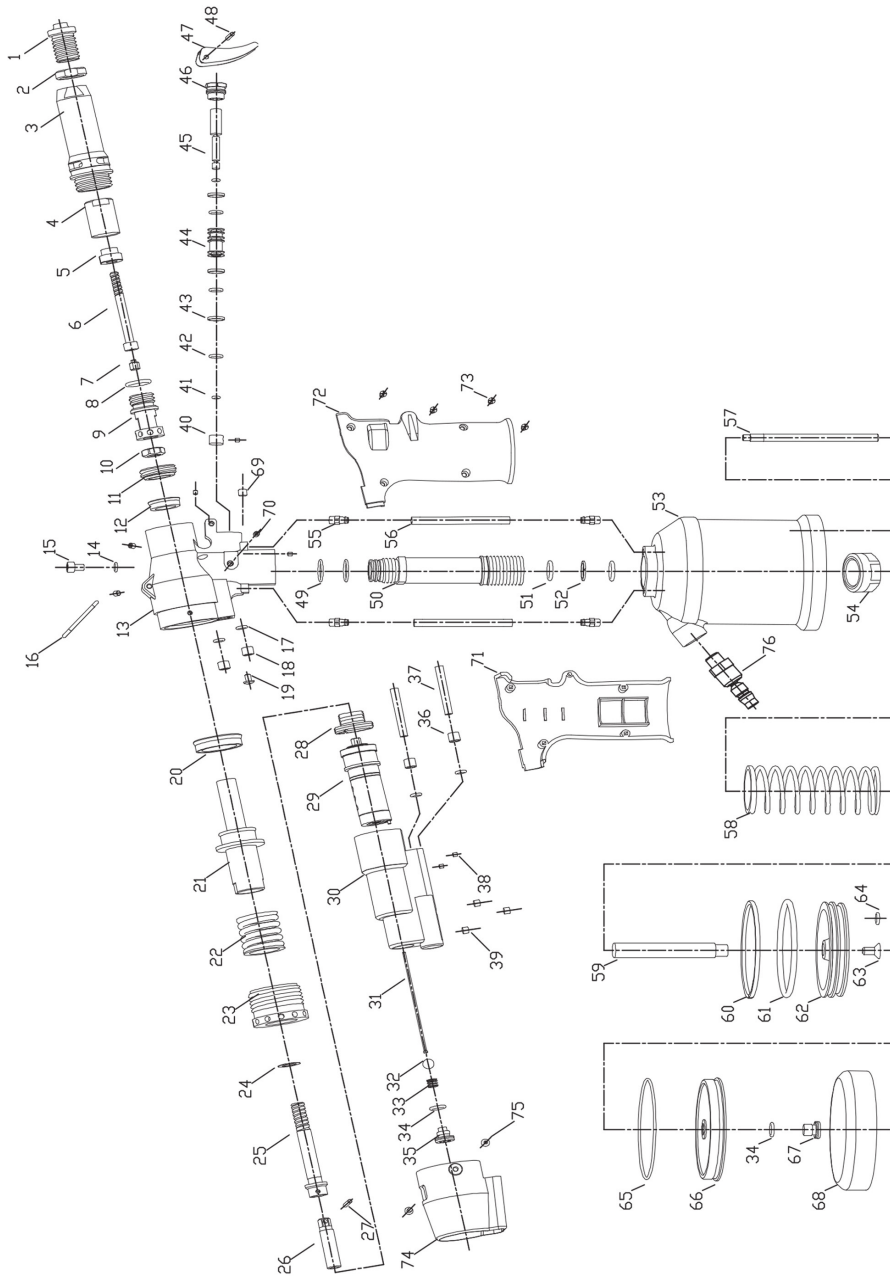

PARTS LIST

NO.	DESCRIPTION	CODE
1A	F10 Anvil M3	F10-01A
1B	F10 Anvil M4	F10-01B
1C	F10 Anvil M5	F10-01C
1D	F10 Anvil M6	F10-01D
1E	F10 Anvil M8	F10-01E
1F	F10 Anvil M10	F10-01F
2	F10 Lock-Nut for Anvil M3-M10	F10-02
3	F10 Anvil Holder M3-M10	F10-03
4	Holder for Mandrel & Spacer	F10-04
5A	Spacer for M3 Mandrel	F10-05A
5B	Spacer for M4 Mandrel	F10-05B
5C	Spacer for M5 Mandrel	F10-05C
5D	Spacer for M6 Mandrel	F10-05D
5E	Spacer for M8 Mandrel	F10-05E
5F	Spacer for M10 Mandrel	F10-05F
6A	F10 Mandrel-M3 x 50	F10-06A
6B	F10 Mandrel-M4 x 60	F10-06B
6C	F10 Mandrel-M5 x 60	F10-06C
6D	F10 Mandrel-M6 x 60	F10-06D
6E	F10 Mandrel-M8 x 65	F10-06E
6F	F10 Mandrel-M10 x 60	F10-06F
7A	F10 Driveshaft M3	F10-07A
7B	F10 Driveshaft M4	F10-07B
7C	F10 Driveshaft M5	F10-07C
7D	F10 Driveshaft M6	F10-07D
7E	F10 Driveshaft M8	F10-07E
7F	F10 Driveshaft M10	F10-07F
9	F10 Spindle	F10-09
10	Retaining Nut for Spindle	F10-10
11	Retaining Nut for Piston Rod	F10-11
12	F10 Lip-Seal	F10-12
15	F10 Bleed Screw	F10-15
74	Stroke adjust Protector	F10-74
75	Button Screw	F10-75