

OPERATION MANUAL

RIVTEC® MODEL LN-5 Industrial & Heavy Duty HAND RIVET NUT & ★ RIVET BOLT/STUD TOOL With Auto-Open Design™ & Detachable Easy-Turn Unit™



- This Illustrated Operation Manual includes the FEATURES, SPECIFICATIONS, PARTS LIST, OPERATION INSTRUCTIONS, MAINTENANCE and TROUBLESHOOTING.
- Before operating this TOOL, please MUST read this Illustrated OPERATION MANUAL carefully to ensure Safe, Correct and Satisfactory Operation.
- ★ LN-5 can be also served as the RIVET BOLT/STUD TOOL with the Optional THREADED SOCKETS on request.

● PATENTS USA US 9,162,278 B2 GERMANY 20 2014 102 094.2 TAIWAN I 551371
中国 实用新型专利 ZL 2013 2 0300246.1 WORLDWIDE PATENTS PENDING

RIVTEC® Model LN-5 *Industrial & Heavy Duty* HAND RIVET NUT TOOL

With Auto-Open Design™ & Detachable Easy-Turn Unit™

A. FEATURES

- **LN-5 RIVET NUT TOOL** is designed to fasten **RIVET NUTS** with the **THREADED MANDRELS**, from M5x0.8 up to M12X1.75 or from 10-24/10-32 up to 1/2-13, firmly and to build up enough **Female Threads** securely in the thin base metals and pipes with weldless, tapping-free and one-side work in order to fasten with **Bolts**.
- **LN-5** is also designed to set **RIVET BOLTS/STUDS** with the optional **THREADED SOCKETS**, from M5x0.8 up to M8x1.25 or from 10-24/10-32 up to 5/16-18, firmly and to build up enough **Male Threads** securely on the thin base metals and pipes with weldless and one-side work in order to fasten with **Nuts**.
- **LN-5** is equipped with Innovative **Auto-Open Design™** for convenient operation, and Innovative **Detachable Easy-Turn Unit** for easy replacement of **Easy-Turn Unit**.
- **LN-5** is equipped with a **Detachable Easy-Turn Unit Design™**, just turn the ROTATING KNOB to drive the THREADED MANDREL or THREADED SOCKET to engage with and release from RIVET NUT or RIVET BOLT/STUD easily.
- **LN-5** is equipped with an innovative **FIXING-HOLES DEVICE™**, simply inserts the FIXING-HOLE PIN not only to solve the headache problem of RIVET NUT stuck on the working THREADED MANDREL or RIVET BOLT/STUD stuck in the working THREADED SOCKET that might happen when engaging with or fastening RIVET NUT or RIVET BOLT/STUD, but also to assist THREADED MANDREL or THREADED SOCKET to mount to or dismount from the TOOL easily just with a single SERVICE WRENCH.

B. SPECIFICATIONS

- **LN-5 Tool Dimensions and Net Weight:**
Dimensions(Closed type): L 530 x W 150 mm, L 20-7/8" x W 5-7/8". Net Weight: 1.83 kg, 4.03 lb.
- **LN-5 Working Capacity:**
 - 1) RIVET NUTS/THREADED INSERTS Materials: Aluminum, Steel, Stainless Steel/Inox ISO Metric Thread Size: M4X0.7, M5x0.8, M6x1.0, M8x1.25, M10x1.5. **Or** UN Inch Thread Size: 8-32, 10-24, 10-32, 1/4-20, 5/16-18, 3/8-16.
 - 2) RIVET NUTS/THREADED INSERTS Materials: Aluminum, Steel ISO Metric Thread Size: M12X1.75. **Or** UN Inch Thread Size: 1/2-13.
 - *3) RIVET BOLTS/STUDS Materials: Aluminum, Steel, Stainless Steel/Inox ISO Metric Thread Size: M5x0.8, M6x1.0, M8x1.25. **Or** UN Inch Thread Size: 10-24, 10-32, 1/4-20, 5/16-18.

* LN-5 can fasten RIVET BOLTS/STUDS with the optional THREADED SOCKETS on request.
- **LN-5 Standard Parts:**
 - 1) THREADED MANDRELS:
ISO Metric Thread Size: M5x0.8, M6x1.0, M8x1.25, M10x1.5, M12x1.75: 1 pc of each. **Or** UN Inch Thread Size: 10-24, 10-32, 1/4-20, 5/16-18, 3/8-16, 1/2-13: 1 pc of each.
 - 2) NOSEPIECES:
ISO Metric Size: M5, M6, M8, M10, M12: 1 pc of each. **Or** UN Inch Size: #10, 1/4, 5/16, 3/8, 1/2: 1 pc of each.
 - 3) NOSEPIECE LOCK NUT, SERVICE WRENCH, SMALL RULE, FIXING-HOLE PIN, PIN RETAINER, PARTS PLASTIC BOX, TRAY & STEEL CARRY CASE or PLASTIC CARRY CASE, OPERATION MANUAL: 1 pc of each.
- **LN-5 Optional Parts:**
 - 1) THREADED MANDRELS: M4x0.7 or 8-32.
 - 2) THREADED SOCKETS (To fasten RIVET BOLTS/STUDS):
ISO Metric Thread Size: M5x0.8, M6x1.0, M8x1.25. **Or** UN Inch Thread Size: 10-24, 10-32, 1/4-20, 5/16-18.

RIVTEC® Model LN-5 *Industrial & Heavy Duty* HAND RIVET NUT TOOL

With Auto-Open Design™ & Detachable Easy-Turn Unit™

C. PARTS LIST

PATENTS & WORLDWIDE PATENT PENDING

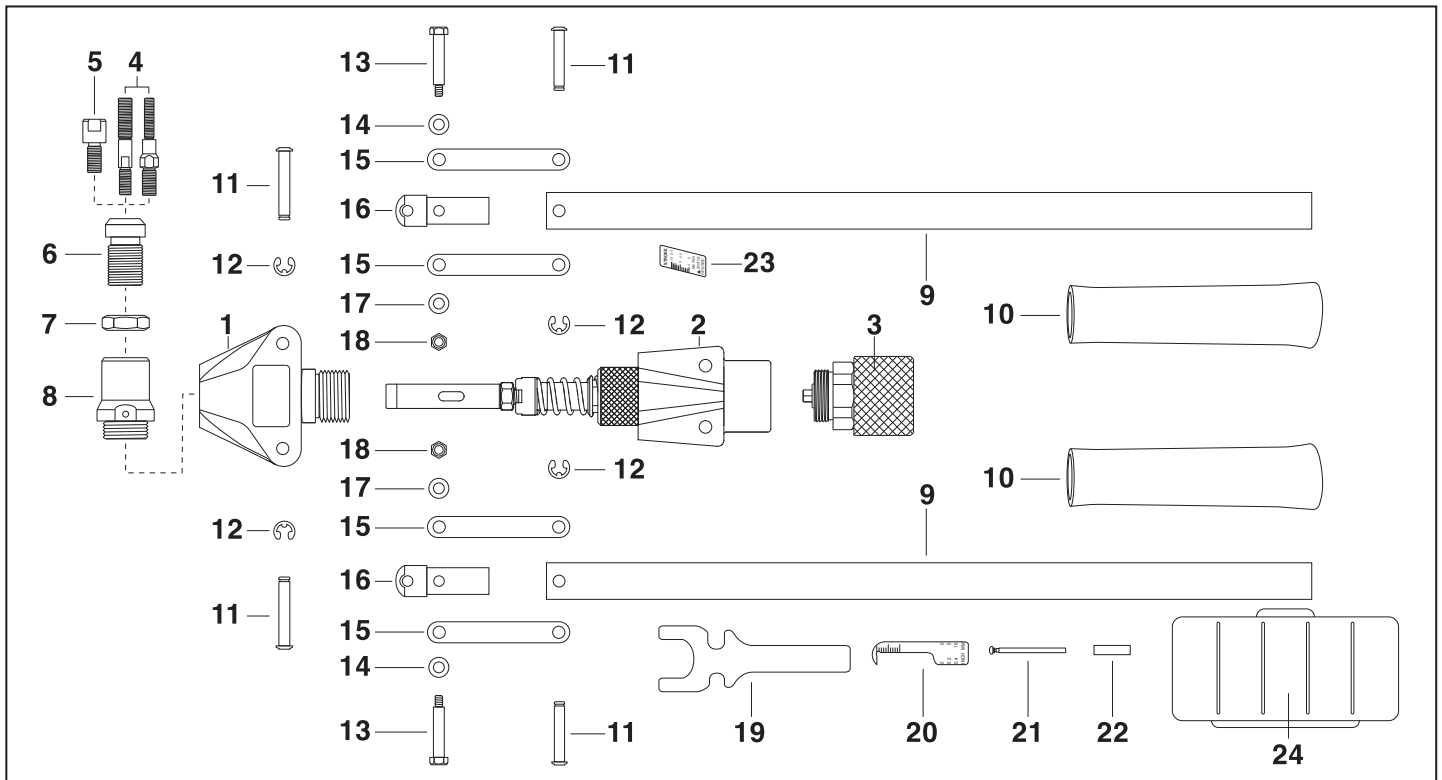

No.	Part No.	Part Name
1	LN5-01	Front Body
2	LN5-02	Rear Body Assembly
3	LN5-03	Easy-Turn Unit, Complete Set
• 4-M407	LN5-04M407	Threaded Mandrel, M4x0.7 (Option)
• 4-M508	LN5-04M508	Threaded Mandrel, M5x0.8
• 4-M610	LN5-04M610	Threaded Mandrel, M6x1.0
• 4-M8125	LN5-04M8125	Threaded Mandrel, M8x1.25
• 4-M1015	LN5-04M1015	Threaded Mandrel, M10x1.5
• 4-M12175	LN5-04M12175	Threaded Mandrel, M12x1.75
• 4-832	LN5-04832	Threaded Mandrel, 8-32 (Option)
• 4-1024	LN5-041024	Threaded Mandrel, 10-24
• 4-1032	LN5-041032	Threaded Mandrel, 10-32
• 4-1420	LN5-041420	Threaded Mandrel, 1/4-20
• 4-51618	LN5-0451618	Threaded Mandrel, 5/16-18
• 4-3816	LN5-043816	Threaded Mandrel, 3/8-16
• 4-1213	LN5-041213	Threaded Mandrel, 1/2-13
• 5-M508	LN5-05M508	Threaded Socket, M5x0.8 (Option)
• 5-M610	LN5-05M610	Threaded Socket, M6x1.0 (Option)
• 5-M8125	LN5-05M8125	Threaded Socket, M8x1.25 (Option)
• 5-1024	LN5-051024	Threaded Socket, 10-24 (Option)
• 5-1032	LN5-051032	Threaded Socket, 10-32 (Option)
• 5-1420	LN5-051420	Threaded Socket, 1/4-20 (Option)
• 5-51618	LN5-0551618	Threaded Socket, 5/16-18 (Option)
• 6-M4	LN5-06M4	Nosepiece, for M4 (Option)
• 6-M5	LN5-06M5	Nosepiece, for M5
• 6-M6	LN5-06M6	Nosepiece, for M6
• 6-M8	LN5-06M8	Nosepiece, for M8
• 6-M10	LN5-06M10	Nosepiece, for M10
• 6-M12	LN5-06M12	Nosepiece, for M12

No.	Part No.	Part Name
• 6-8	LN5-0608	Nosepiece, for #8 (Option)
• 6-10	LN5-0610	Nosepiece, for #10
• 6-14	LN5-0614	Nosepiece, for 1/4"
• 6-516	LN5-06516	Nosepiece, for 5/16"
• 6-38	LN5-0638	Nosepiece, for 3/8"
• 6-12	LN5-0612	Nosepiece, for 1/2"
• 7	LN5-07	Nosepiece Lock Nut
8	LN5-08	Head
9	LN5-09	Handle
10	LN5-10	Grip
11	LN5-11	Pin, L329
12	LN5-12	Snap Ring
13	LN5-13	Bolt, L252
14	LN5-14	Washer, 12x6
• 15	LN5-15	Arm
16	LN5-16	Joint
17	LN5-17	Washer, 10x5
18	LN5-18	Nylon Nut, M5
19	LN5-19	Service Wrench
20	LN5-20	Small Rule
21	LN5-21	Fixing-Hole Pin
22	LN5-22	Pin Retainer
23-MA	LN5-23MA	Stroke Indicator, Metric & Inch Sizes
23-A	LN5-23A	Stroke Indicator, Inch Size
24	LN5-24	Parts Plastic Box
25	LN5-25	Steel Carry Case (Not Shown)
26	LN5-26	Tray (Not Shown)
27	LN5-27	Plastic Carry Case (Not Shown)

REMARKS:

- means Wearing Parts or Possible Missing Parts.
- Threaded Mandrels are for setting Rivet Nuts.
Optional Threaded Sockets are for setting Rivet Bolts/Studs.
- Each Nosepiece can set same size of Rivet Nut and Rivet Bolt/Stud.
For example, LN5-06M6 Nosepiece can set both M6 Rivet Nut and M6 Rivet Bolt/stud.
- Ordering example: LN-5 LN5-04M8125, M8x1.25 Threaded Mandrel, 10 pcs.

RIVTEC® Model LN-5 *Industrial & Heavy Duty* HAND RIVET NUT TOOL

With Auto-Open Design™ & Detachable Easy-Turn Unit™

D. MAIN PARTS NAME

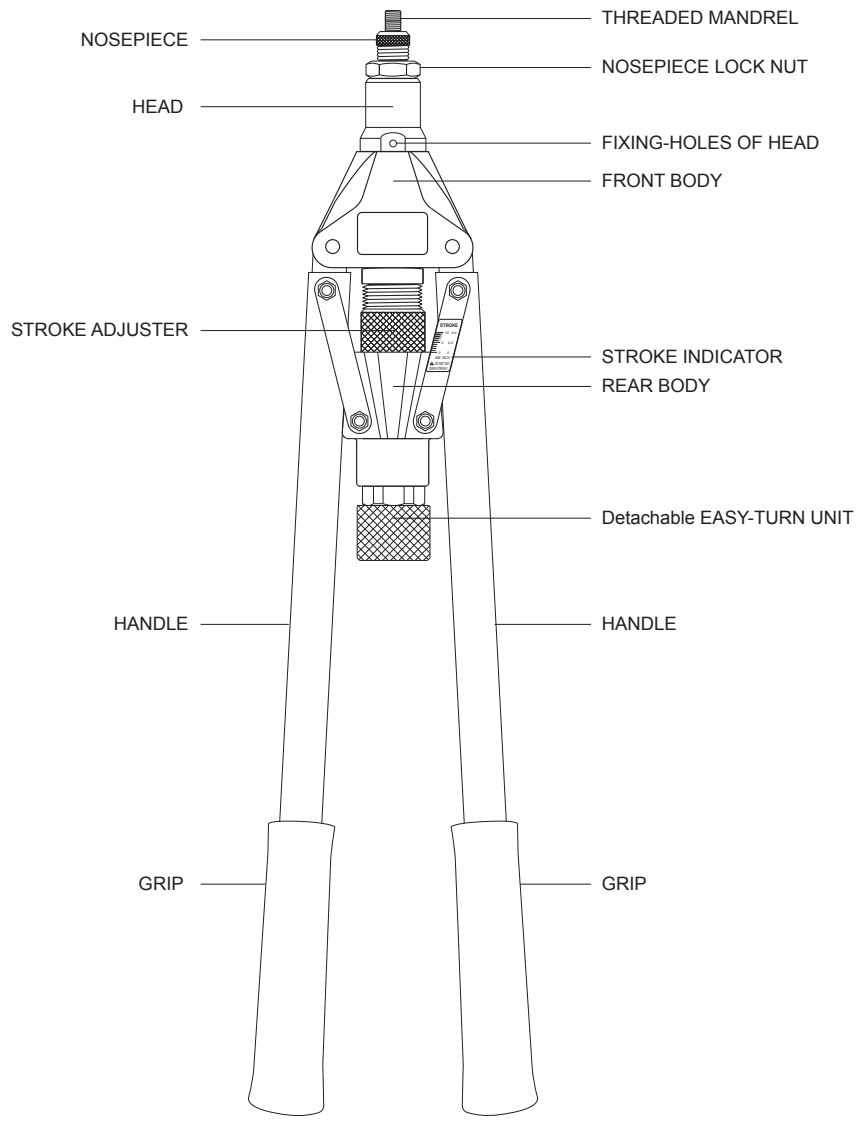
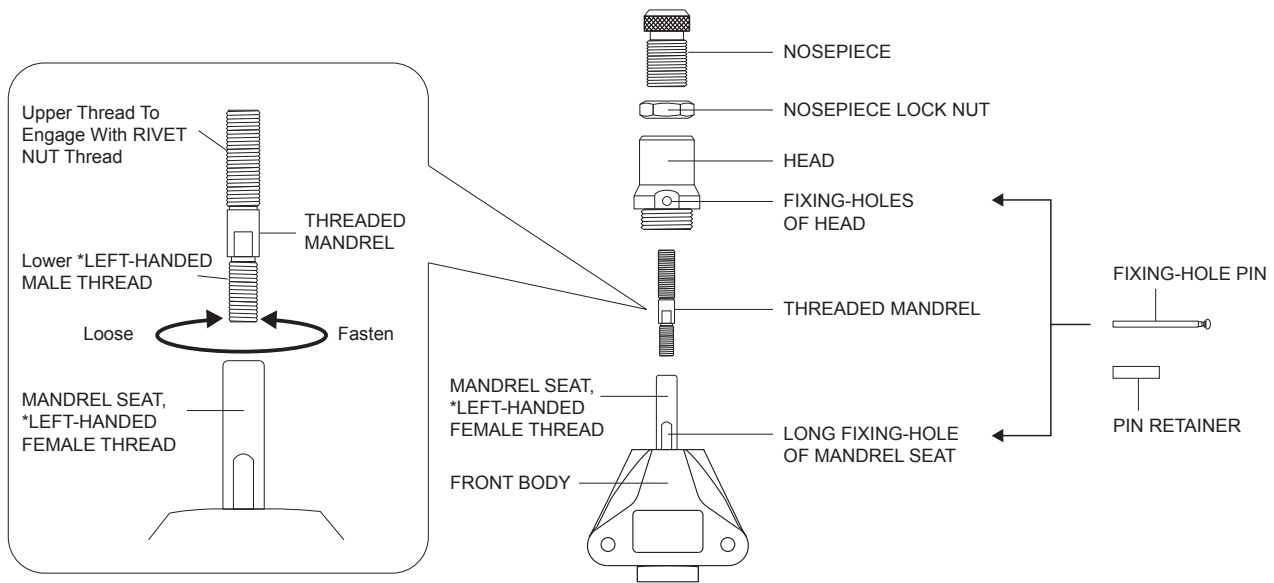

E. HOW TO CHANGE THREADED MANDREL AND NOSEPIECE

PRECAUTION :

Check the Thread Size of Fastening BOLT and WORKPIECE Thickness to determine the Thread Size, Grip Range, Material and Type of RIVET NUT, then drill or punch the correct size of Hole in the WORKPIECE to fasten RIVET NUT. The Working Size of THREADED MANDREL and NOSEPIECE should be same as the Thread Size of RIVET NUT.

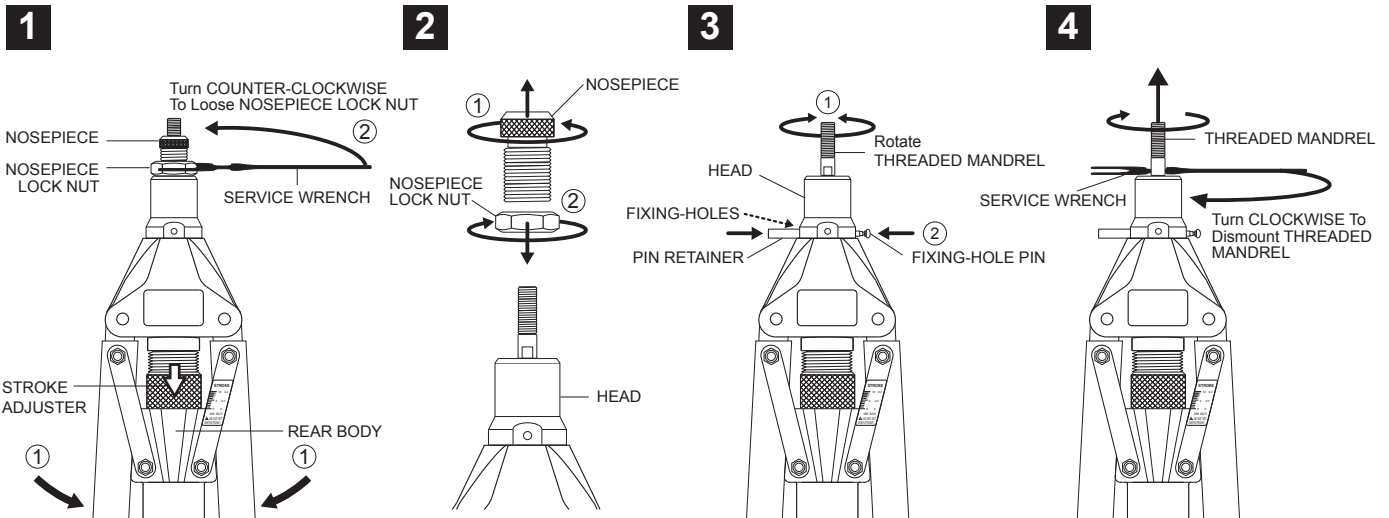

Close 2 HANDLES completely by turning down STROKE ADJUSTER until it touches the REAR BODY①. Use SERVICE WRENCH to loose NOSEPIECE LOCK NUT by turning Counter-Clockwise②.

Use Hand to unscrew NOSEPIECE and NOSEPIECE LOCK NUT from HEAD①, then dismount NOSEPIECE LOCK NUT from NOSEPIECE②.

Use Hand to rotate THREADED MANDREL to align 2 FIXING-HOLES of HEAD with inside LONG FIXING-HOLE of MANDREL SEAT①, then insert FIXING-HOLE PIN through the FIXING-HOLES and put PIN RETAINER onto FIXING-HOLE PIN End②. The free rotation of MANDREL SEAT is locked.

Use SERVICE WRENCH and Hand to loose and dismount THREADED MANDREL from MANDREL SEAT by turning Clockwise. (NOTE: MANDREL SEAT has Left-Handed Female Threads.)

Now the TOOL is ready for changing another size of THERADED MANDREL and NOSEPIECE.

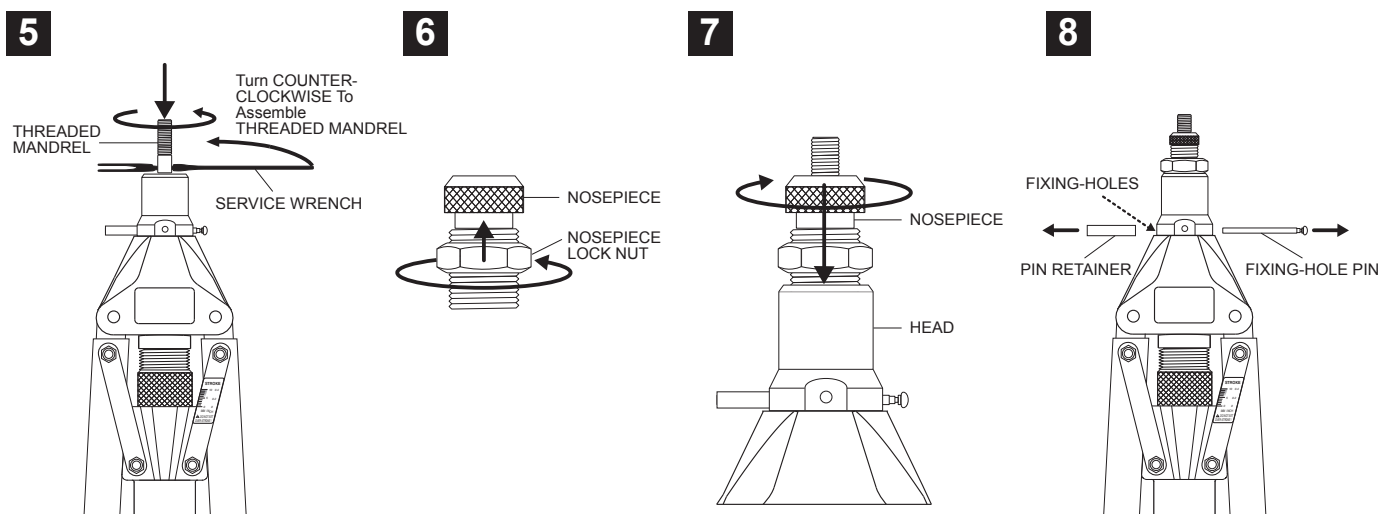

Use Hand and SERVICE WRENCH to assemble the working size of THREADED MANDREL into MANDREL SEAT firmly by turning Counter-Clockwise. (NOTE: MANDREL SEAT has Left-Handed Female Threads.)

Use Hand to assemble NOSEPIECE LOCK NUT onto the working size of NOSEPIECE.

Use Hand to screw NOSEPIECE into HEAD by turning Clockwise.

Finally, take off PIN RETAINER and pull FIXING-HOLE PIN from the FIXING-HOLES.

F. HOW TO ADJUST THE PROPER STROKE DISTANCE

[WARNING]

- The proper Stroke Distance is decided as per the WORKPIECE Thickness and the Grip Range of RIVET NUT. Each RIVET NUT has its own Grip Range, the Maximum Grip and Minimum Grip.
- The WORKPIECE Thickness must be WITHIN the Grip Range of RIVET NUT or BETWEEN the Maximum Grip and Minimum Grip of RIVET NUT for safe and firm fastening.
- If the Maximum Grip of RIVET NUT is SMALLER than the WORKPIECE Thickness, this TOOL and RIVET NUT Threads might be damaged.
- If the Minimum Grip of RIVET NUT is LARGER than the WORKPIECE Thickness, this RIVET NUT cannot be gripped firmly in the WORKPIECE.
- Adjusting TOO LONG Stroke Distance might damage this TOOL and RIVET NUT Threads, while TOO SHORT Stroke Distance cannot fasten RIVET NUT firmly in the WORKPIECE.

1

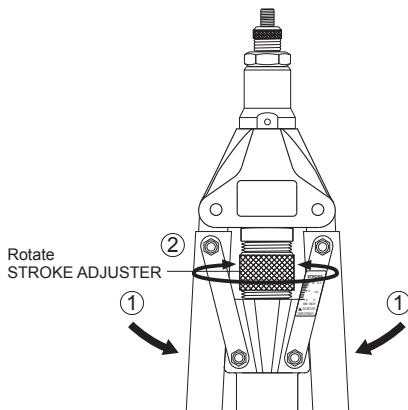

Close 2 HANDLES completely ①, rotate STROKE ADJUSTER ② to adjust the proper Stroke Distance in 2 popular ways.

2

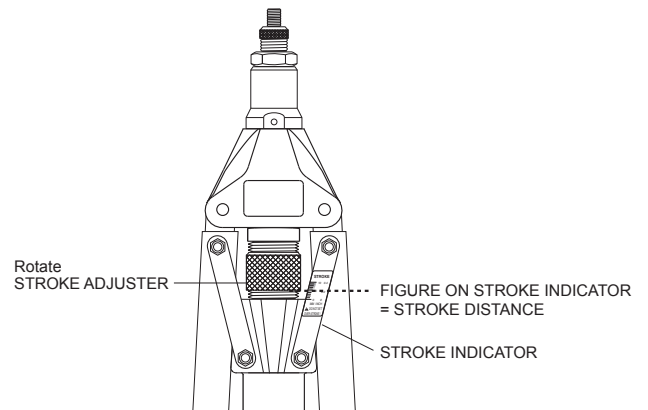

First Way: Rotate STROKE ADJUSTER to find out the Figure on the STROKE INDICATOR parallel with the Bottom Edge of the STROKE ADJUSTER:

Figure on STROKE INDICATOR = Stroke Distance

3

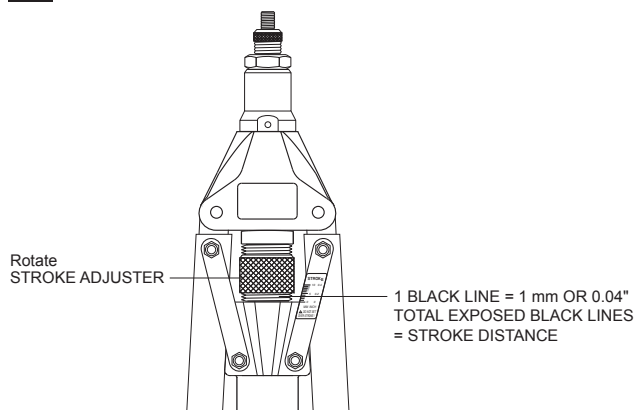

Second Way: Rotate STROKE ADJUSTER to find out the Total Exposed Black Lines of the STROKE INDICATING LINES:

1 Black Line = 1 mm or 0.04" Stroke Distance
Total Exposed Black Lines = Stroke Distance

NOTE

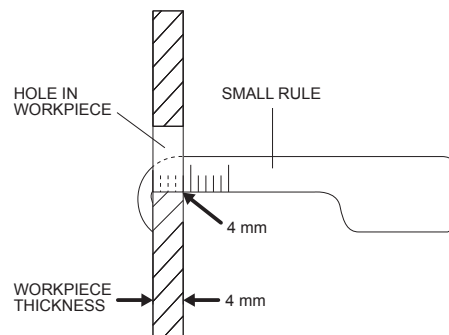

NOTE: The SMALL RULE is specially designed to measure the WORKPIECE Thickness.

G. HOW TO ADJUST THE PROTRUDING LENGTH (L) OF THREADED MANDREL

1

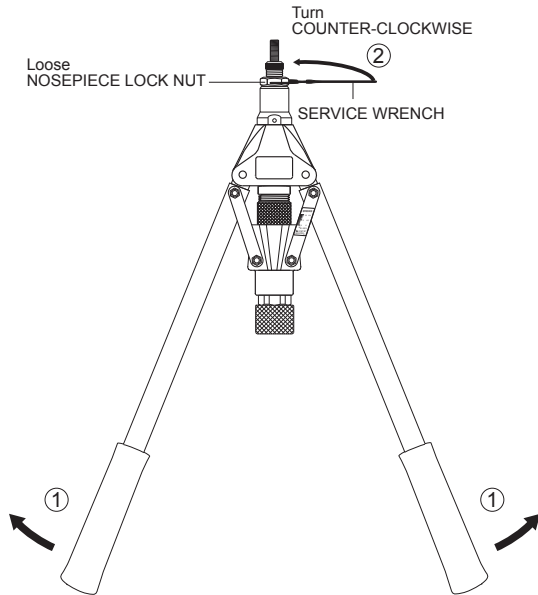

Open 2 HANDLES fully ①, use SERVICE WRENCH to loosen NOSEPIECE LOCK NUT by turning Counter-Clockwise ②.

2

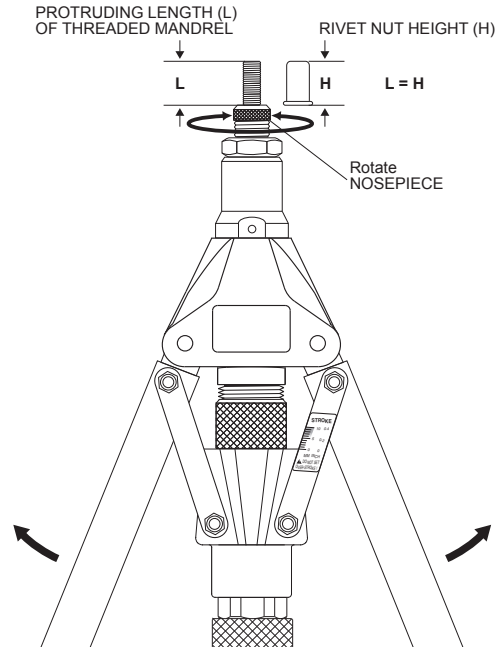

Use Hand to rotate NOSEPIECE to adjust the **Protruding Length (L) of THREADED MANDREL** to be same as the **RIVET NUT Height (H)**, $L = H$.

3

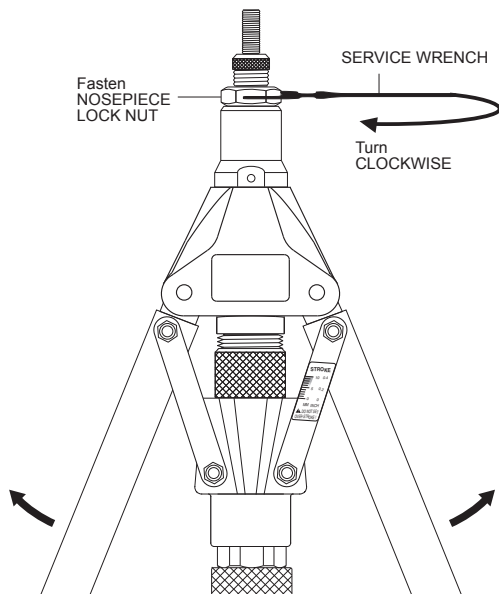

Finally use SERVICE WRENCH to fasten NOSEPIECE LOCK NUT by turning Clockwise.

NOTE

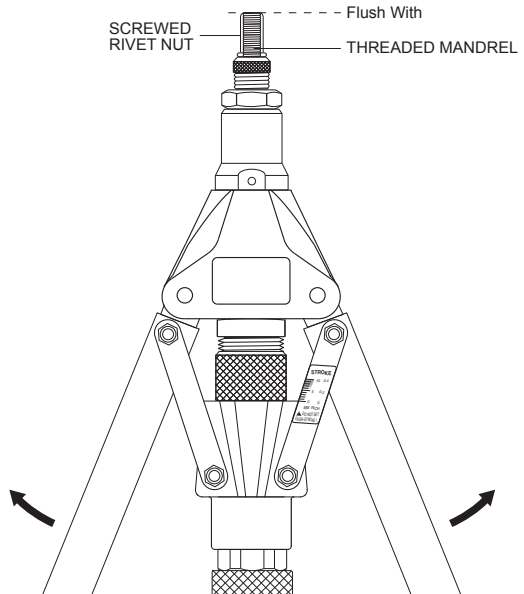

NOTE: After adjusting the Protruding Length (L) of THREADED MANDREL, the Screwed RIVET NUT should be flush with the Top of THREADED MANDREL.

H. HOW TO OPERATE THIS TOOL TO FASTEN RIVET NUT

PRECAUTION:

Before operating this TOOL, it is strongly requested to follow the above "E" to install the correct size of **THREADED MANDREL** and **NOSEPIECE**, the above "F" to adjust the proper **Stroke Distance**, and the above "G" to adjust the **Protruding Length (L)** of **THREADED MANDREL** to ensure perfect fastening work between **TOOL** and **RIVET NUT**.

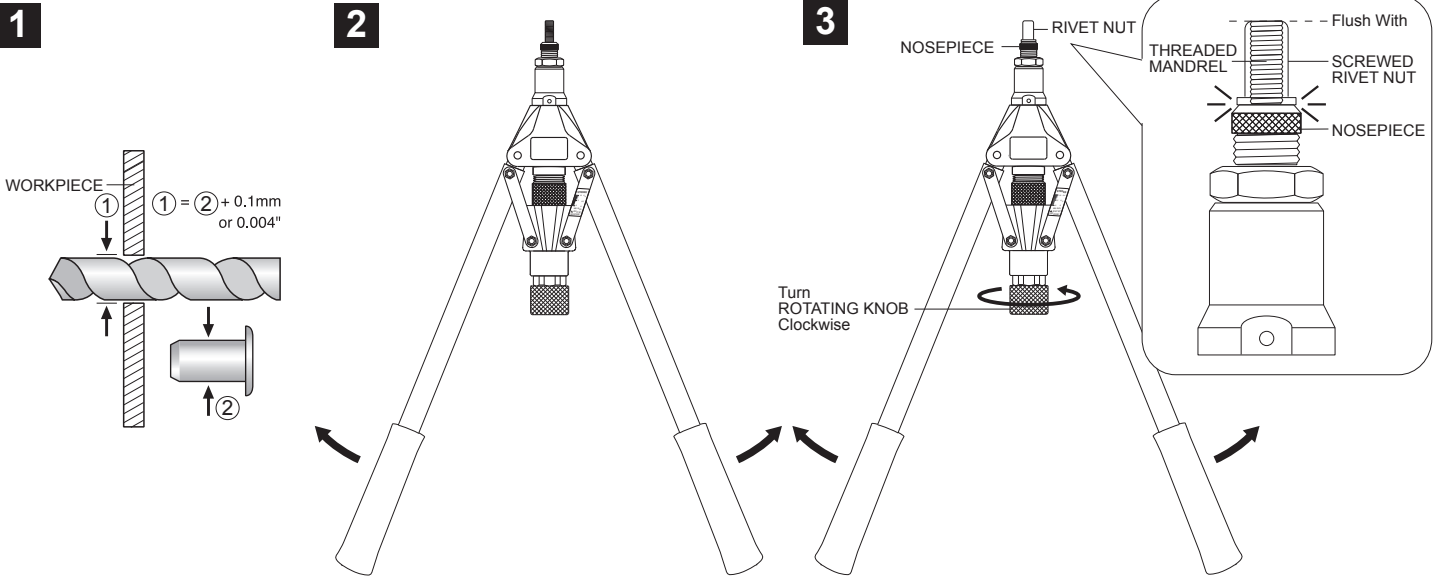

Drill or punch a Hole on **WORKPIECE**, Hole diameter ① should be 0.1 mm or 0.004" larger than **RIVET NUT** diameter ②.

Open 2 **HANDLES** fully.

Turn **ROTATING KNOB** Clockwise to screw **RIVET NUT** onto **THREADED MANDREL** until **RIVET NUT** touches **NOSEPIECE**. It is strongly suggested the **RIVET NUT** to touch the **NOSEPIECE** Slightly, **NOT HEAVILY!** The **Screwed RIVET NUT** should be flush with the **THREADED MANDREL**.

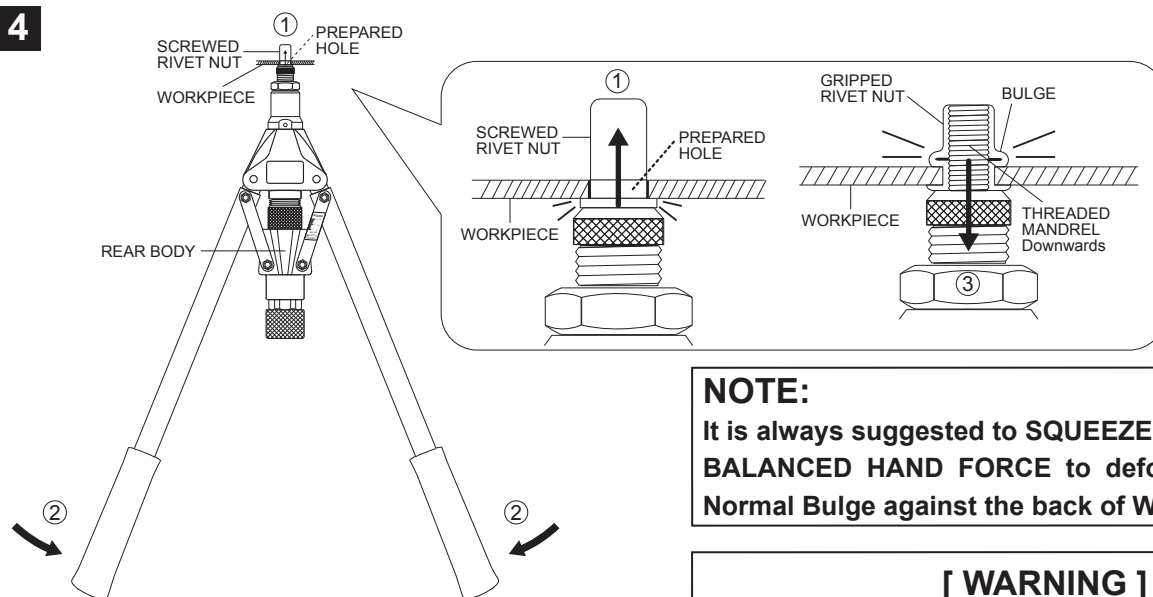

Insert the **Screwed RIVET NUT** into the **Prepared Hole** of **WORKPIECE** to touch **WORKPIECE** ①. Squeeze 2 **HANDLES** to touch **REAR BODY** ②, that drives **THREADED MANDREL** downwards ③ to deform **RIVET NUT** a **Bulge** against the back of **WORKPIECE** to fasten **RIVET NUT** in the **WORKPIECE**.

NOTE:

It is always suggested to **SQUEEZE 2 HANDLES WITH BALANCED HAND FORCE** to deform **RIVET NUT** a **Normal Bulge** against the back of **WORKPIECE**.

[WARNING]

If hand force **CAN NOT** squeeze 2 **HANDLES** to touch **REAR BODY**, **DO NOT CONTINUE TO SQUEEZE 2 HANDLES**, it may be caused by **TOO LONG Stroke Distance**. **REDUCE** The **Stroke Distance** immediately to protect this precious **TOOL** and **RIVET NUT Thread** from damage. See **TROUBLESHOOTING K-2**).

H. HOW TO OPERATE THIS TOOL TO FASTEN RIVET NUT

5

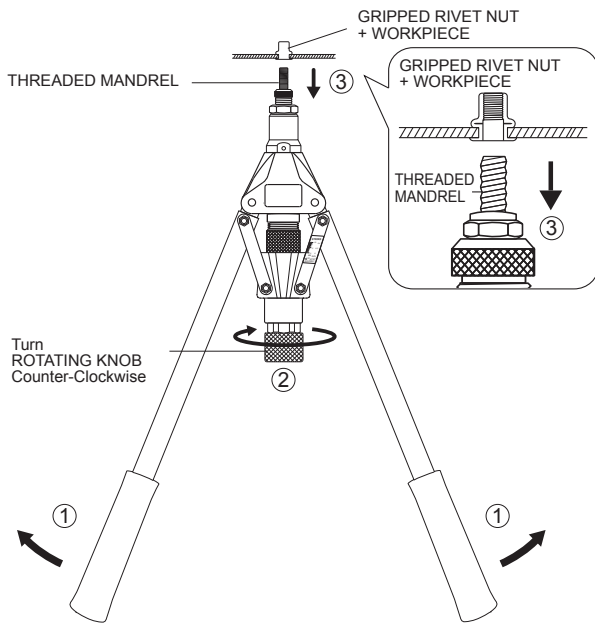

Open 2 HANDLES fully ①, turn ROTATING KNOB Counter-Clockwise ② to unscrew THREADED MANDREL from the GrippED RIVET NUT completely ③.

6

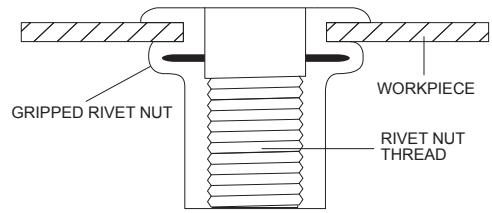

The RIVET NUT is therefore gripped in the WORKPIECE firmly and the RIVET NUT Thread is built up securely.

NOTES:

IF THE RIVET NUT IS NOT FASTENED FIRMLY, please refer to the TROUBLESHOOTING K-1).
IF 2 HANDLES CAN NOT BE SQUEEZED TO TOUCH REAR BODY, please refer to the TROUBLESHOOTING K-2).

7

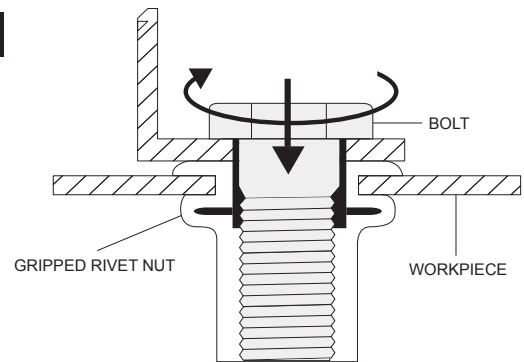

Complete the fastening work with a Bolt or a Screw to the GrippED RIVET NUT.

I. HOW TO FASTEN THE SAME SIZE OF RIVET NUT

If the next gripping RIVET NUT is same size as the previous one, just repeat the above "H" steps.

Don't Need Any Adjustment!

NOTE:

The PILOT TEST is always recommended before setting different sizes of RIVET NUT for perfect fastening work and protecting this precious TOOL and RIVET NUT Thread from damage.

J. MAINTENANCE

This TOOL is a very sturdy and reliable tool, it only requires occasional Light Oil applied to the Thread of the THREADED MANDREL ①, NOSEPIECE ② and STROKE ADJUSTER ③.

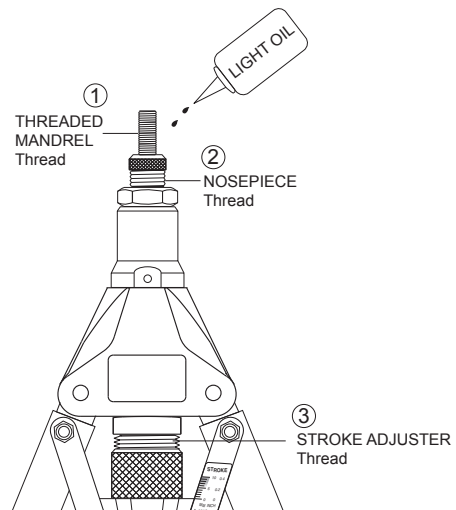

WARNING



**For SAFETY WORK,
ALWAYS WEAR
SAFETY GOGGLES.**

K. TROUBLESHOOTING

K-1) IF THE RIVET NUT IS NOT SET FIRMLY AT THE FIRST FASTENING OPERATION, HOW TO RE-SET THE RIVET NUT FIRMLY:

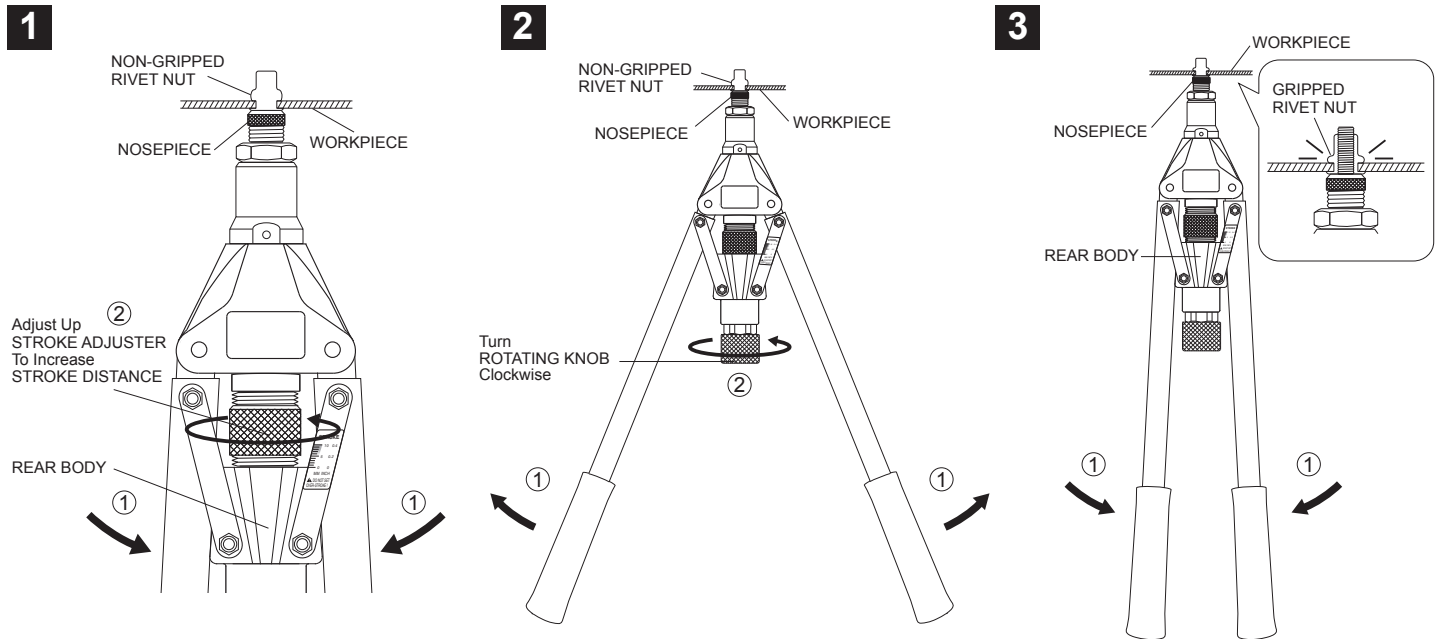

Still hold to squeeze 2 HANDLES to touch REAR BODY ①, adjust the STROKE ADJUSTER upwards ② to increase the Stroke Distance 1.0mm or 0.04" step by step.

Open 2 HANDLES fully ①, turn ROTATING KNOB Clockwise until RIVET NUT touches NOSEPIECE Slightly ②.

Squeeze 2 HANDLES ① to grip again RIVET NUT until 2 HANDLES touch REAR BODY and RIVET NUT is set firmly. If RIVET NUT is still not set firmly, repeat the above steps until RIVET NUT is set firmly.

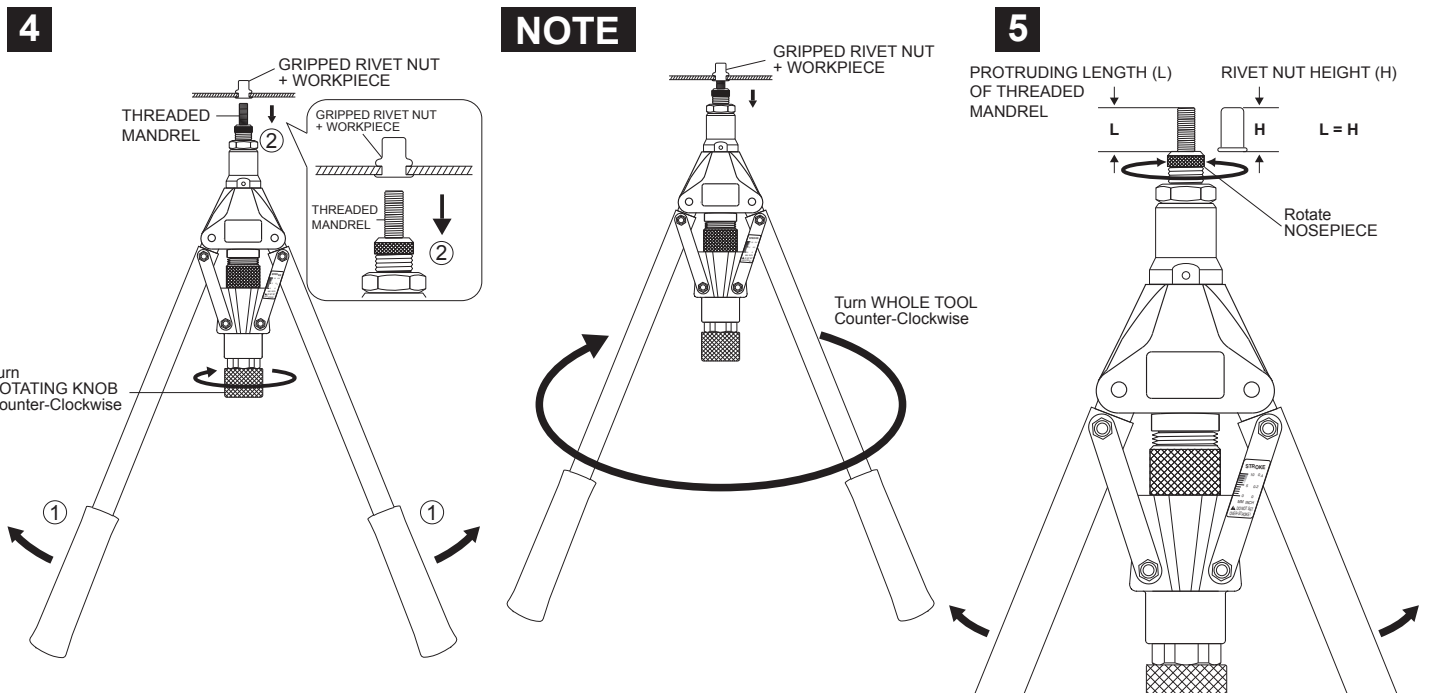

Open 2 HANDLES fully ①, turn ROTATING KNOB Counter-Clockwise to unscrew THREADED MANDREL from the Grippled RIVET NUT and WORKPIECE ②.

NOTE: If the THREADED MANDREL still can not unscrew from the Grippled RIVET NUT and WORKPIECE, turn whole TOOL Counter-Clockwise to unscrew THREADED MANDREL completely.

As the proper Stroke Distance has been re-adjusted, the Protruding Length (L) of THREADED MANDREL needs to be adjusted again to be same as RIVET NUT Height (H), $L = H$, as per the above "G" instruction.

K. TROUBLESHOOTING

K-2) IF STROKE IS ADJUSTED TOO LONG AND HAND FORCE CAN NOT SQUEEZE 2 HANDLES TO TOUCH REAR BODY, HOW TO RE-ADJUST THE CORRECT STROKE DISTANCE TO PROTECT THIS TOOL AND RIVET NUT THREAD FROM DAMAGE:

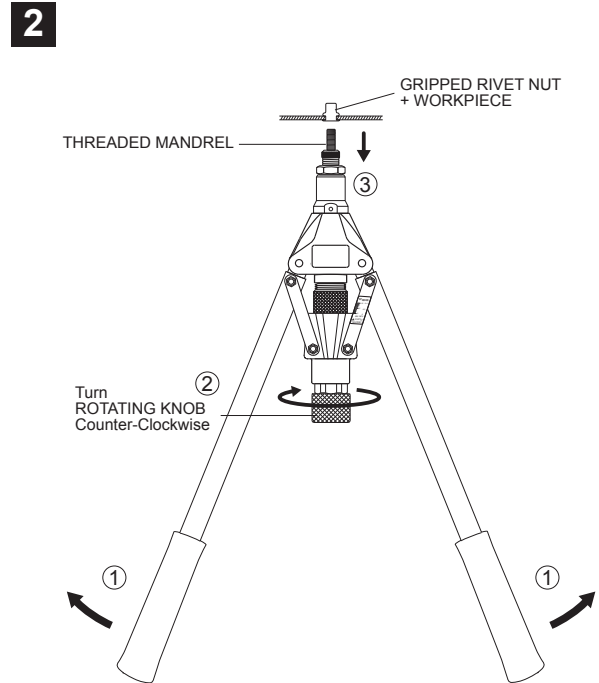
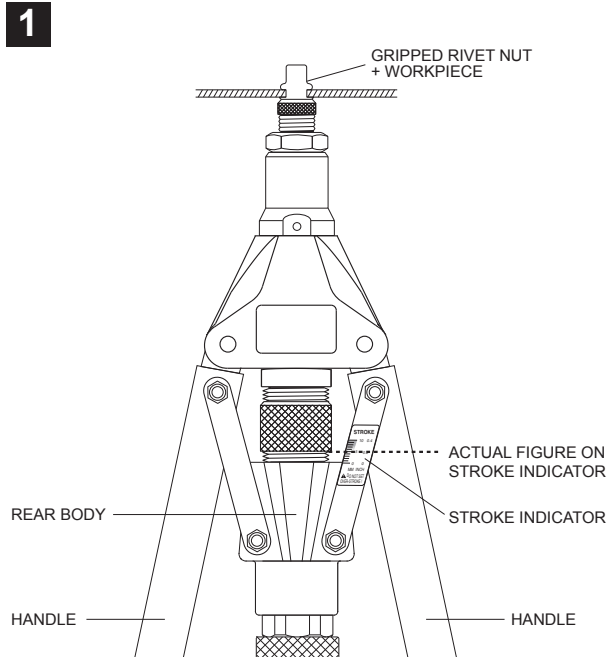

WARNING

DO NOT CONTINUE TO SQUEEZE 2 HANDLES!
DO NOT CONTINUE TO SQUEEZE 2 HANDLES, still hold 2 HANDLES and find out the “Actual Figure on STROKE INDICATOR” and remember that.

Open 2 HANDLES fully ①, turn ROTATING KNOB Counter-Clockwise ② to unscrew THREADED MANDREL from the Gripped RIVET NUT and WORKPIECE ③.

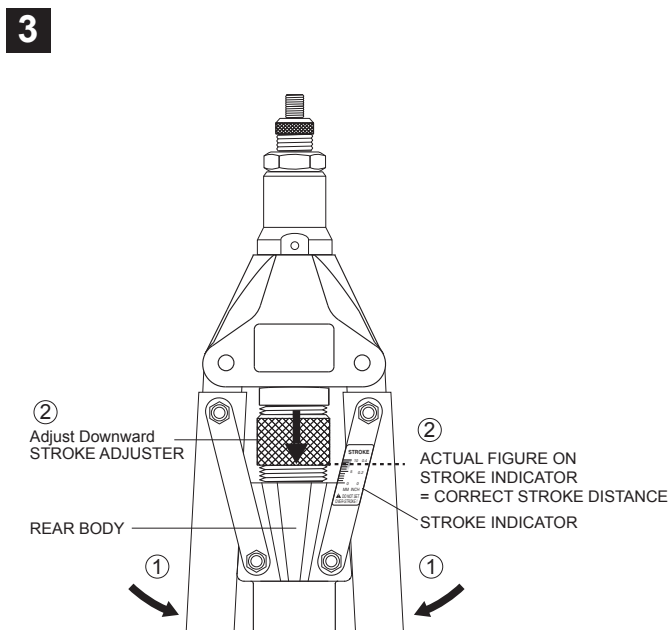

Close 2 HANDLES completely ① to touch REAR BODY, and adjust the STROKE ADJUSTER downward to let Bottom Edge of STROKE ADJUSTER parallel with the “Actual Figure on STROKE INDICATOR” ②. Now the correct Stroke Distance has been re-adjusted.

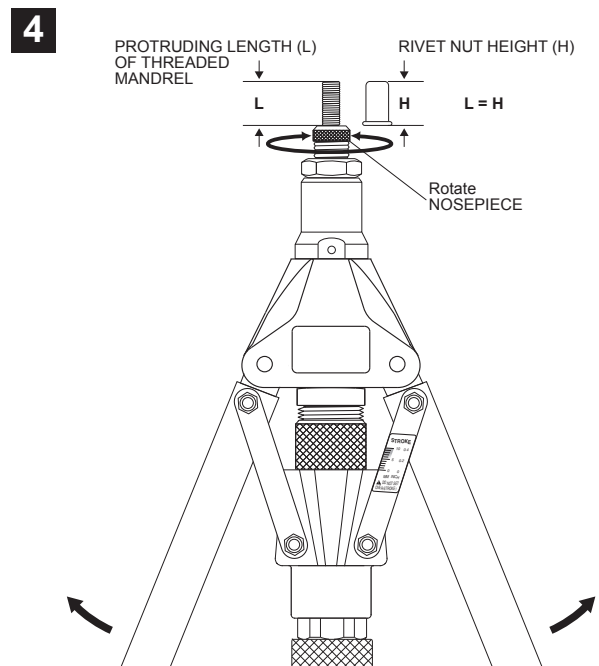

As the Stroke Distance has been re-adjusted, the Protruding Length (L) of THREADED MANDREL needs to be adjusted again to be same as RIVET NUT Height (H), $L = H$, as per the above "G" instruction.

K. TROUBLESHOOTING

K-3) HOW TO SOLVE THE PROBLEM OF RIVET NUT STUCK ON THE THREADED MANDREL WHEN RIVET NUT SCREWS ONTO THREADED MANDREL'S THREADS BY TURNING THE ROTATING KNOB:

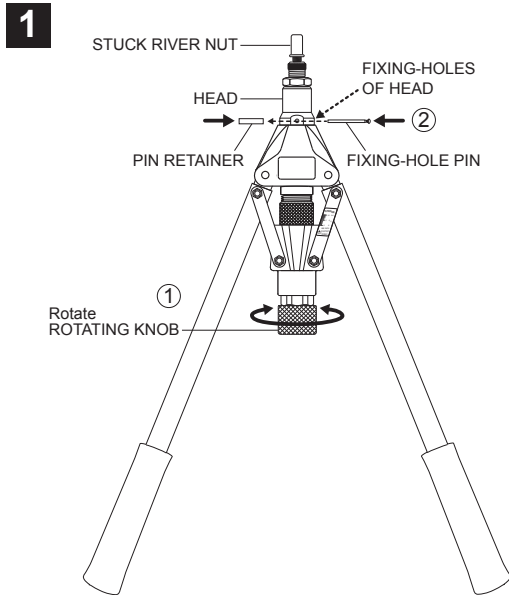

Rotate ROTATING KNOB to align the FIXING-HOLES of HEAD with the inside LONG FIXING-HOLE of MANDREL SEAT ①, then plug the FIXING-HOLE PIN into these FIXING-HOLES and put the PIN RETAINER onto FIXING-HOLE PIN End ②, the free rotation of THREADED MANDREL is therefore stopped.

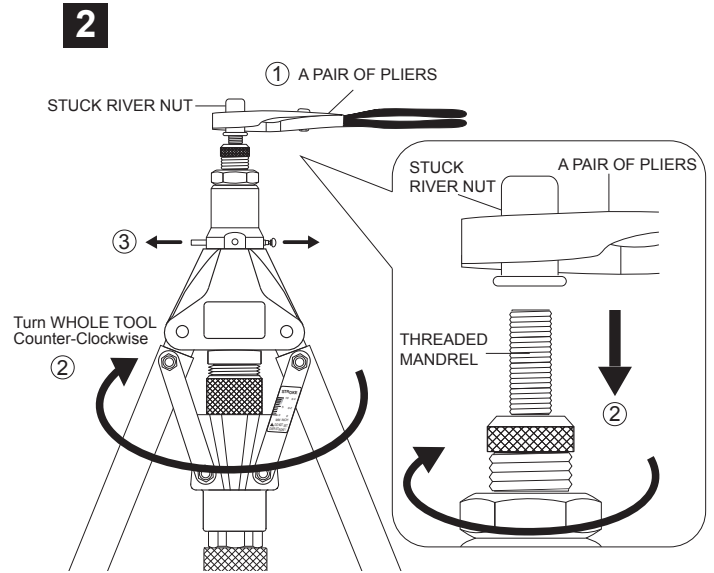

One person uses A Pair of Pliers to clamp the Stuck RIVET NUT ①, and another person turns whole TOOL Counter-Clockwise to unscrew the THREADED MANDREL from the Stuck RIVET NUT ②. Finally, take off PIN RETAINER and pull FIXING-HOLE PIN from the FIXING-HOLES ③.

K-4) HOW TO SOLVE THE PROBLEM OF RIVET NUT STUCK ON THE THREADED MANDREL WHEN SQUEEZING 2 HANDLES AND DEFORMING RIVET NUT IN THE WORKPIECE ABNORMALLY:

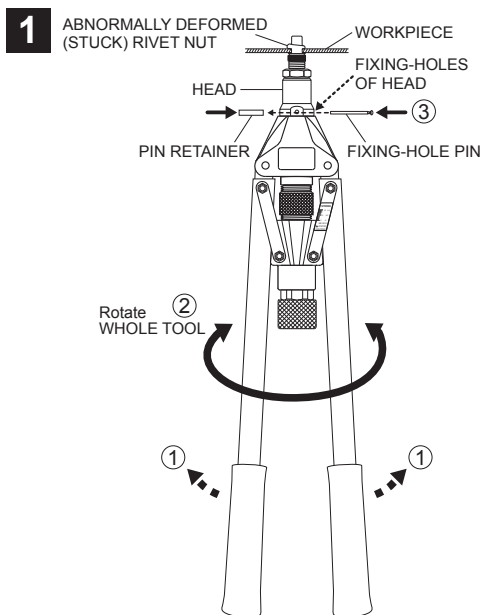

Open 2 HANDLES a little bit ①, rotate whole TOOL to align the FIXING-HOLES of HEAD with the inside LONG FIXING-HOLE of MANDREL SEAT ②, then plug the FIXING-HOLE PIN into these FIXING-HOLES and put the PIN RETAINER onto FIXING-HOLE PIN End ③, the free rotation of THREADED MANDREL is therefore stopped.

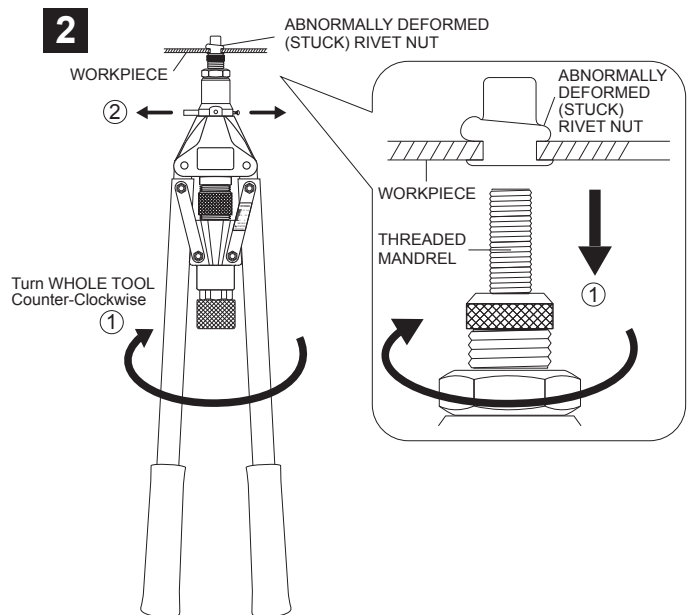

Turn whole TOOL Counter-Clockwise to unscrew THREADED MANDREL from the Stuck RIVET NUT ①. Finally, take off PIN RETAINER and pull FIXING-HOLE PIN from the FIXING-HOLES ②.