

Rivtec® RNT-120

Pneumatic Rivet Nut Tool

The RNT120 is a simple, powerful and cost effective tool capable of installing rivet-nuts in all materials up to M12. This tool will suit a jobbing or repair type environment or a low volume manufacturer.

Stroke length is easily adjustable from 0 - 9mm. Speed of operation can also be reduced for operators needing a precise pull cycle on delicate work pieces.

Setting Capacity

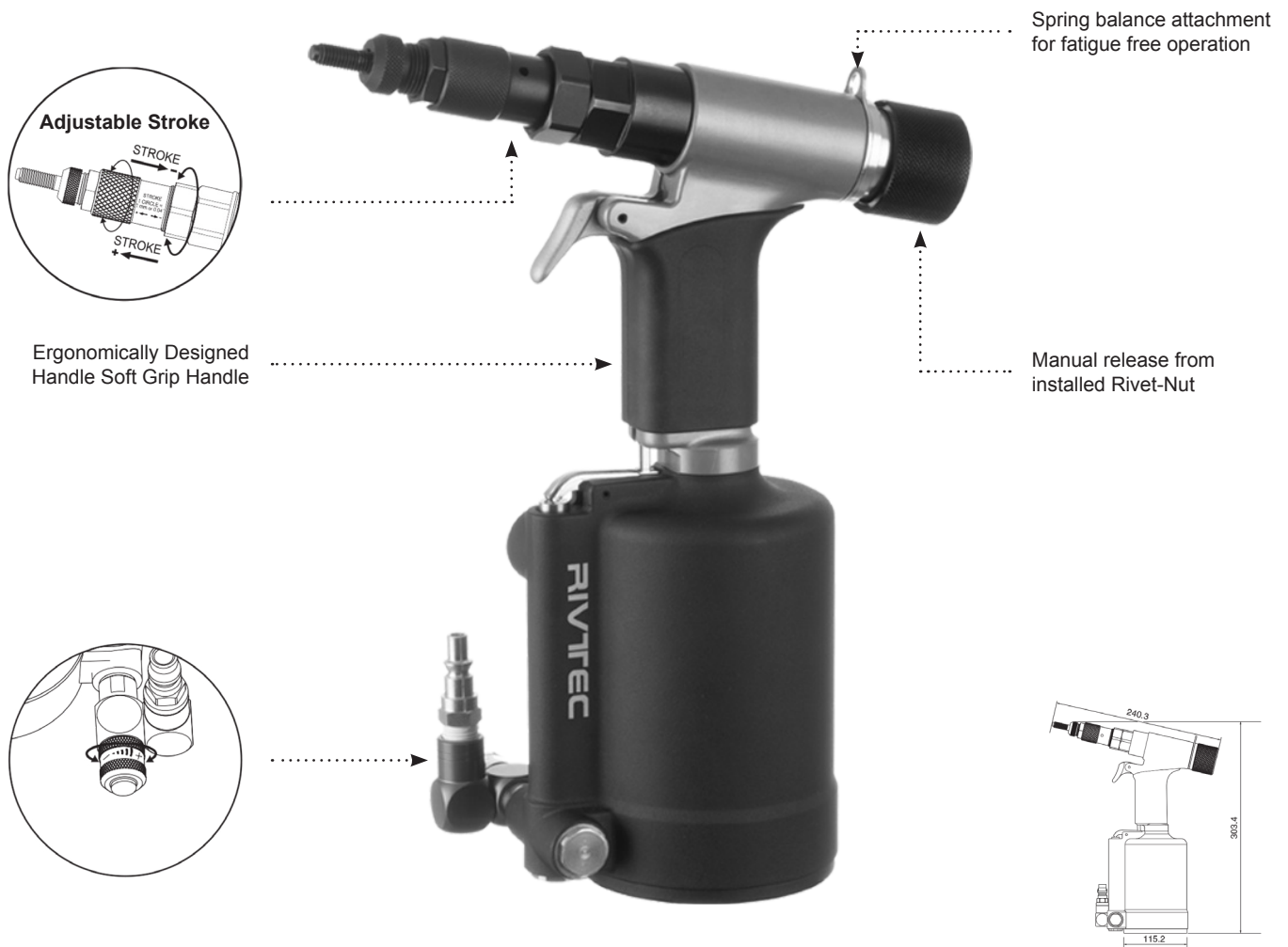
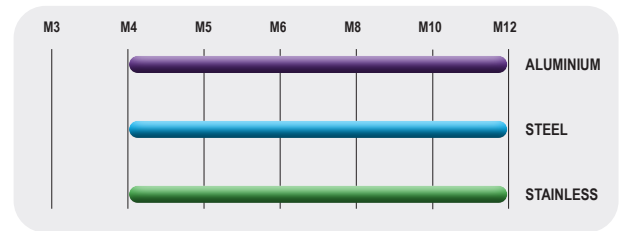

Specifications		Package Contents
Product Code:	RNT-120	Mandrels and Nosepieces for M4, M5, M6, M8 & M10 Rivet Nuts
Weight:	2.30 kg	Service Wrench, Pin Retainer and Material Thickness Ruler
Length (without nose assembly):	240 mm	Hydraulic Oil Bottle and Injector (Supplied without Oil)
Operating Air Pressure:	90 psi 6 bar	Airline Fitting
Pulling Force:	21.0 kN	Operating and Maintenance Manual
Stroke:	9.00 mm	Made in Taiwan