

Distributed by

RIVTEC®

■ **TILA** continuous hinges

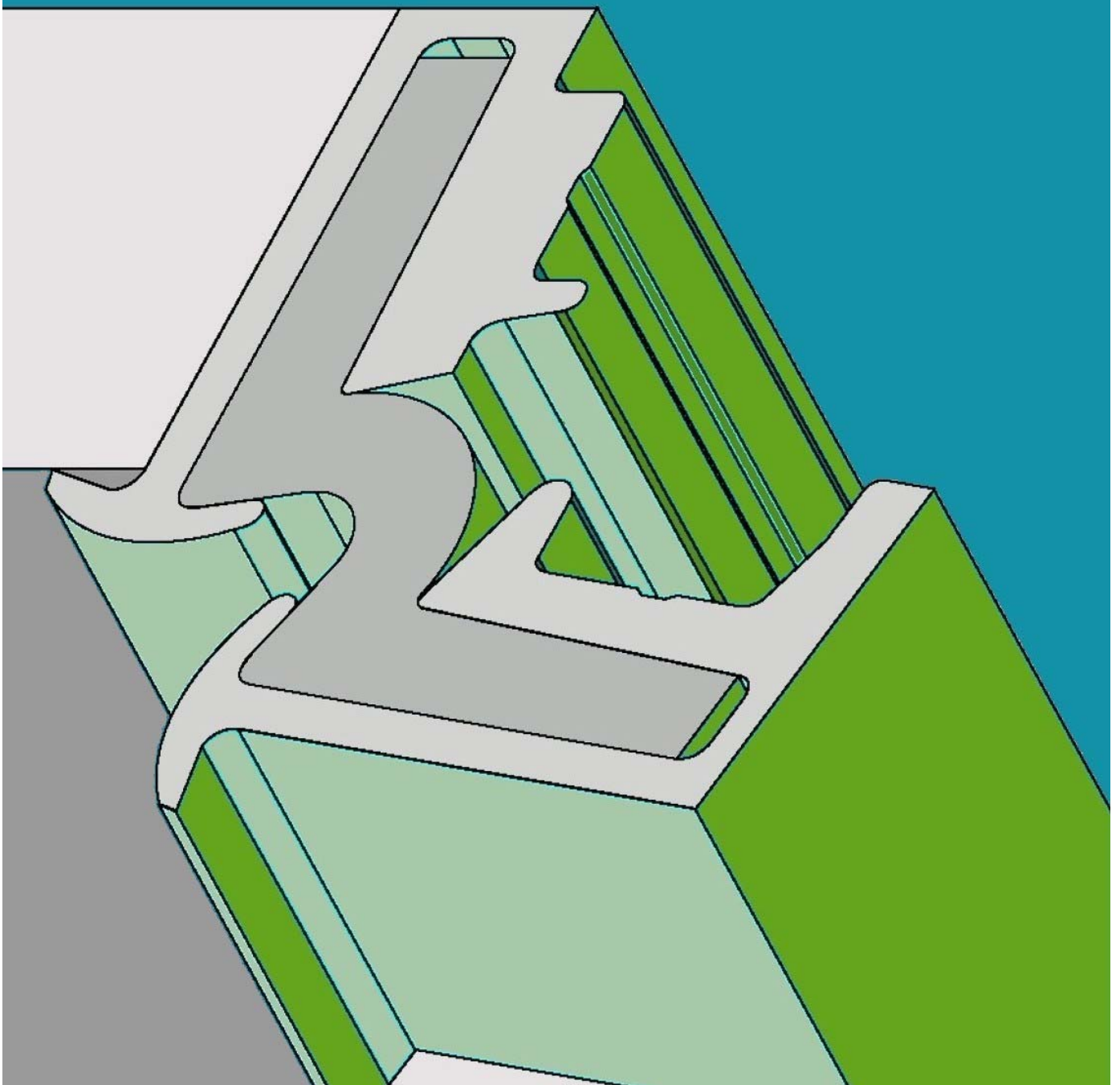

Vehicle Components

Continuous hinges

TILA continuous hinges

TILA continuous hinge

Advantages:

- Suitable for doors, tailgates, covers and flaps.
- Only minimal external protrusion. A contribution towards road safety since the risk of injury caused by dangerous, protruding fittings, is eliminated.
- Hinge and seal all-in-one - along the entire length.
- Absolute precision - when in the closed position the two aluminium profiles interlock together. They can only be dismantled when the door, tailgate, cover are open. Forced entry can only be made by cutting the plastic profile, leaving behind visible evidence.
- Virtually no wear.
- Totally maintenance-free - has been in practical use for more than two decades, primarily in the bodywork and vehicle area, tried and tested.
- Supplied ready-assembled in standard and special lengths (by request).

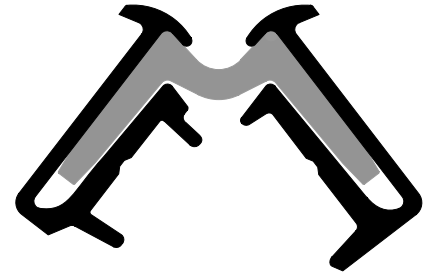

The Function

The „hinge“ takes a specially moulded plastic profile made from a special POLYURETHANE elastomer with permanent elasticity and high tear resistance. Opening angles of more than 180° or 270° are achieved depending upon the profile design.

Continuous stress when in the open position requires the use of a holding mechanism to keep the hing open, e.g. in the case of doors - a Door retainer.

Potential Uses

Can be fitted to doors, tailgates, lids of all kind, as single element or as an add-on unit (for so-called folding or concertina designs), in bodywork and vehicle construction, for boot and van fixings, sales vehicles and buses etc. For use wherever flaps, lids and doors are required.

Installation

Is extremely simple since the TILA continuous hinge is supplied in the open position using spacers and with holes already pre-drilled, ready for installation.

- 1 Attach the TILA continuous hinge to door, flap or lid.
- 2 Fit the installation element to the installation frame and attach the 2nd blade of the TILA continuous hinge to it.
- 3.If you open the door, flap or lid further out the spacers fall out and the door, flap or lid is hinged and ready to use.

As with many "synthetic" materials, care should be taken when subjecting the hinge to specific and specialised influences which may have unexpected detrimental effects. These include, amongst others hydrolysis, microbe infestation, sudden mechanical stresses (e.g. sudden opening) in conjunction with extremely low temperatures, corrosive acids, alkaline solutions and cleaning agent additives.

Moreover, we would ask you to consult us if you have any enquiries so we can provide you with optimum advice. The above mentioned technical data, information and recommendations are intended as a guide but is not binding! These reflect our latest knowledge at the time this product information was submitted for printing and does not exempt the user from carrying out their own precise examination of the potential uses for our products in each individual case.

We reserve the right to carry out design modifications.

The technical data is intended as a guide but is not binding! We reserve the right to carry out design modifications.

Continuous hinges

TILA continuous hinges

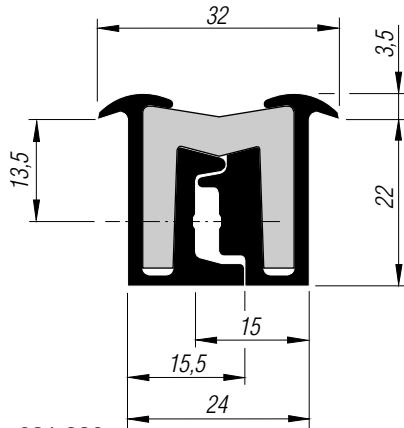
Vehicle Components

631 218 - 631 230

TILA '2200' 22/180° Continuous hinge

Installation width 24, installation depth 22 mm. Pre-drilled hole dia. 4.0 mm, gap 100 mm.

Status of delivery 75° opened.

Temperature resistant from approx. -40°C to approx. +80°C, short periods +120°C without any mechanical damage.

Hydrolysis and bacteria-resistant.

Pack Size: 2 off Sealed in plastic wrapping.

Materials: Aluminium clamping profile AlMgSi 0.5, anodised, E6 EV1, matt silver colour; POLYURETHANE elastomer plastic profile, black.

Length ¹ mm	Number of holes ¹	Wheight approx. kg/each	GTO No.
1800	18	1,900	631 218
2000	20	2,100	631 220
2200	22	2,350	631 222
2400	24	2,550	631 224
2700	27	3,000	631 227
3000	30	3,250	631 230

¹ Special lengths/special bores and distances between holes available on request

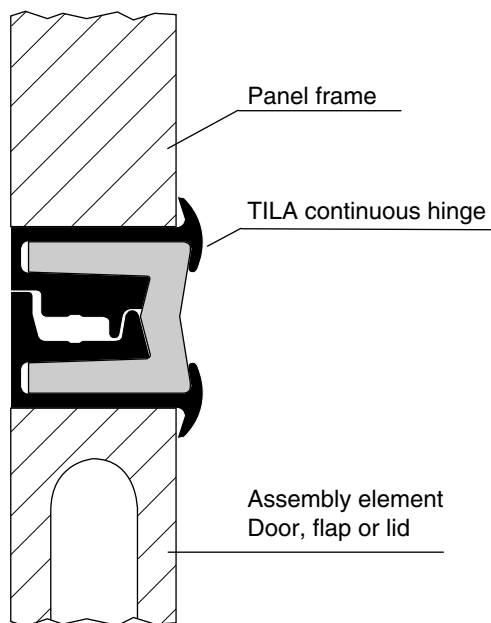

Figure 2

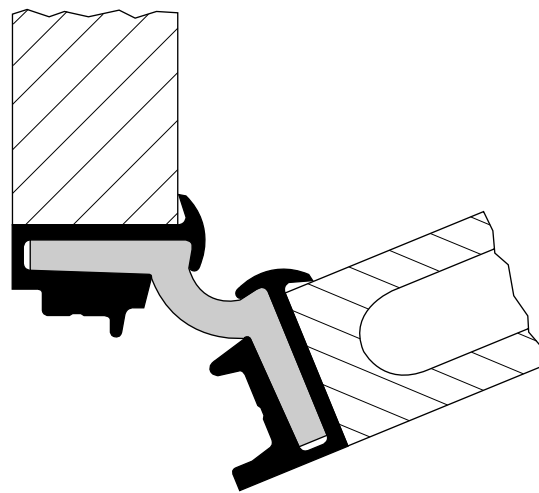

Figure 3

Suggested installation, non-binding - particularly important for flaps and lids.

The TILA 22/180° continuous hinge should be installed as shown in Figure 2 and 3.

Note the correct arrangement of the various aluminium clamping profiles on the panel and assembly element.

TILA continuous hinge drawings shown in the scale of 1:1.

The technical data is for reference only and is not guaranteed! We reserve the right to make design changes.

Vehicle Components

Continuous hinges TILA continuous hinges

TILA '2900' 29/180° Continuous hinge

Installation width 24, installation depth 29 mm. Predrilled hole dia. 5.0 mm, gap 200 mm.

Status of delivery 75° opened.

Temperature resistant from approx. -40°C to approx. +80°C, short periods +120°C without any mechanical damage.

Hydrolysis and bacteria-resistant.

Pack Size: 2 off sealed in plastic wrapping.

Materials: Aluminium clamping profile AlMgSi 0.5, anodised, E6 EV1, matt silver colour; polyurethane elastomer plastic profile, black.

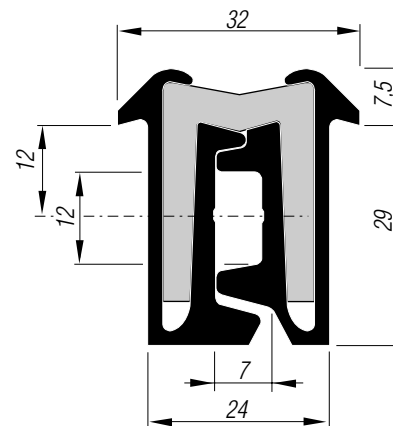

631 238 +631 255

Length ¹ mm	Number of holes ¹	Wheight approx. kg/each	GTO No.
1800	9	2,600	631 238
2000	10	2,900	631 240
2200	11	3,150	631 242
2400	12	3,450	631 244
2500	13	3,800	631 245
2700		4,100	631 247
3000	15	4,600	631 250
3200	11	4,900	631 252
3500	17	5,400	631 255

¹ Special lengths/special bores and distances between holes available on request

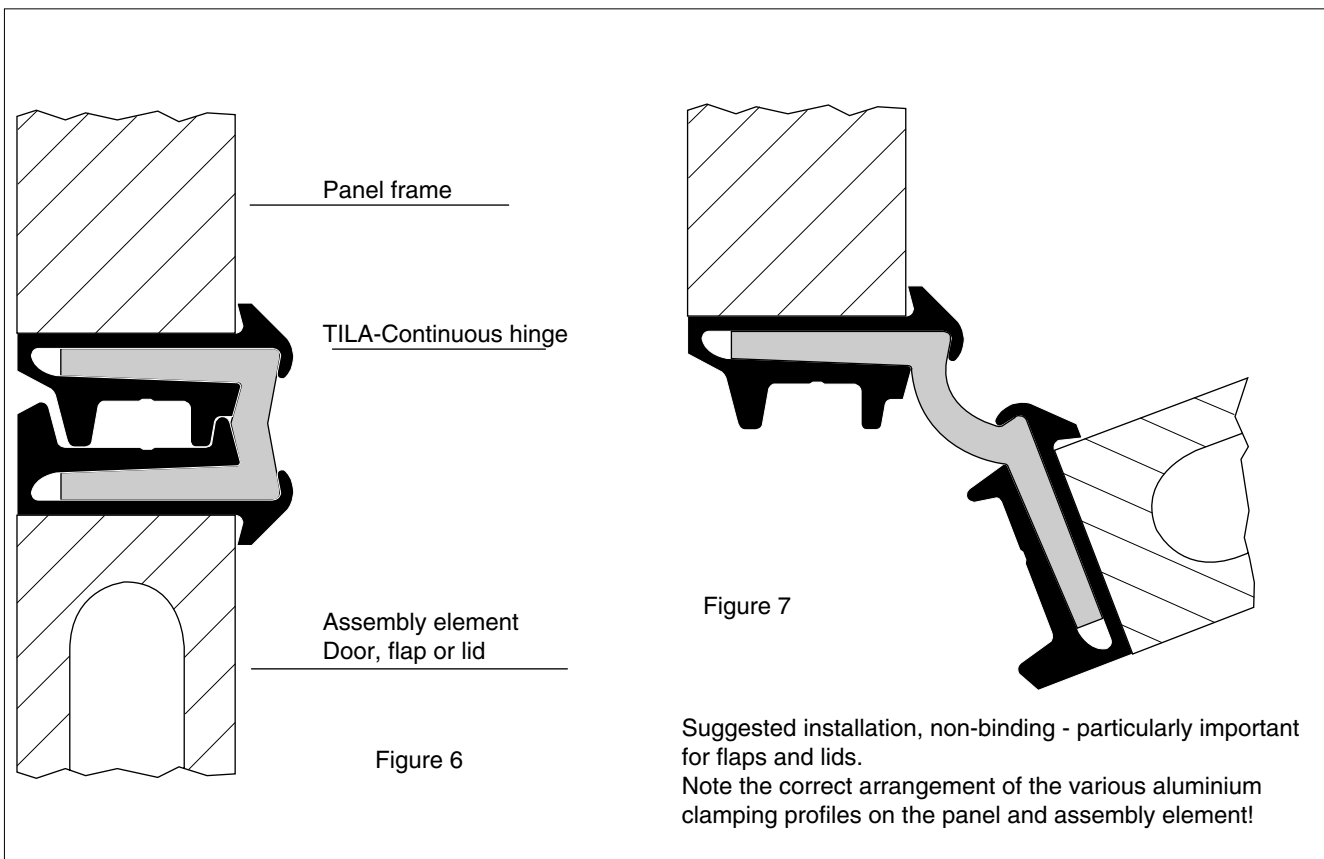

TILA continuous hinge drawings shown in the scale of 1:1.

The technical data is for reference only and is not guaranteed! We reserve the right to make design changes.

Continuous hinges

TILA continuous hinges

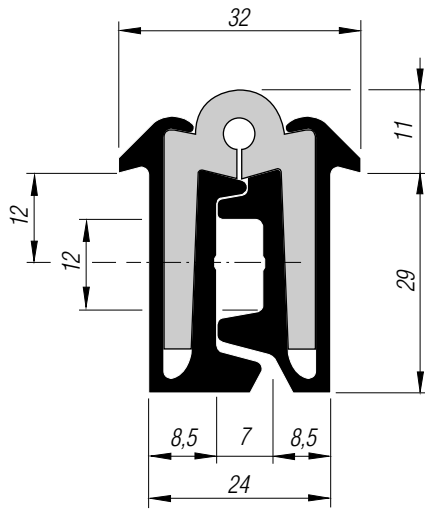
Vehicle Components**TILA „Super“ 29/270° continuous hinge**

This TILA continuous hinge offers a 270° opening angle. The non-binding installation suggestions set out below, using the example of a rear door and frame assembly on a commercial vehicle, clearly show:

- Door outer surface flush with the corner post, giving longer loading area
- „Knuckle“ hinge - rear protrusion only approx. 11 mm: An advantage for trailers with short coupling systems! Installation width 24, installation depth 29 mm. Pre-drilled hole dia. 5.0 mm, gap 200 mm.

Temperature resistant from approx. -40°C to approx. +80°C, short periods +120°C without any mechanical damage.

Hydrolysis and bacteria-resistant.

Pack Size: 2 off sealed in plastic wrapping.

Materials: Aluminium. clamping profile AlMgSi 0.5, anodised, E6 EV1, matt silver colour; POLYURETHANE elastomer plastic profile, black.

Length ¹ mm	Number of holes	Weight approx. kg/each	GTO No.
2200	11	3.230	631 262
2500	13	3.900	631 265
3000	15	4.700	631 270

¹ Special lengths available on request

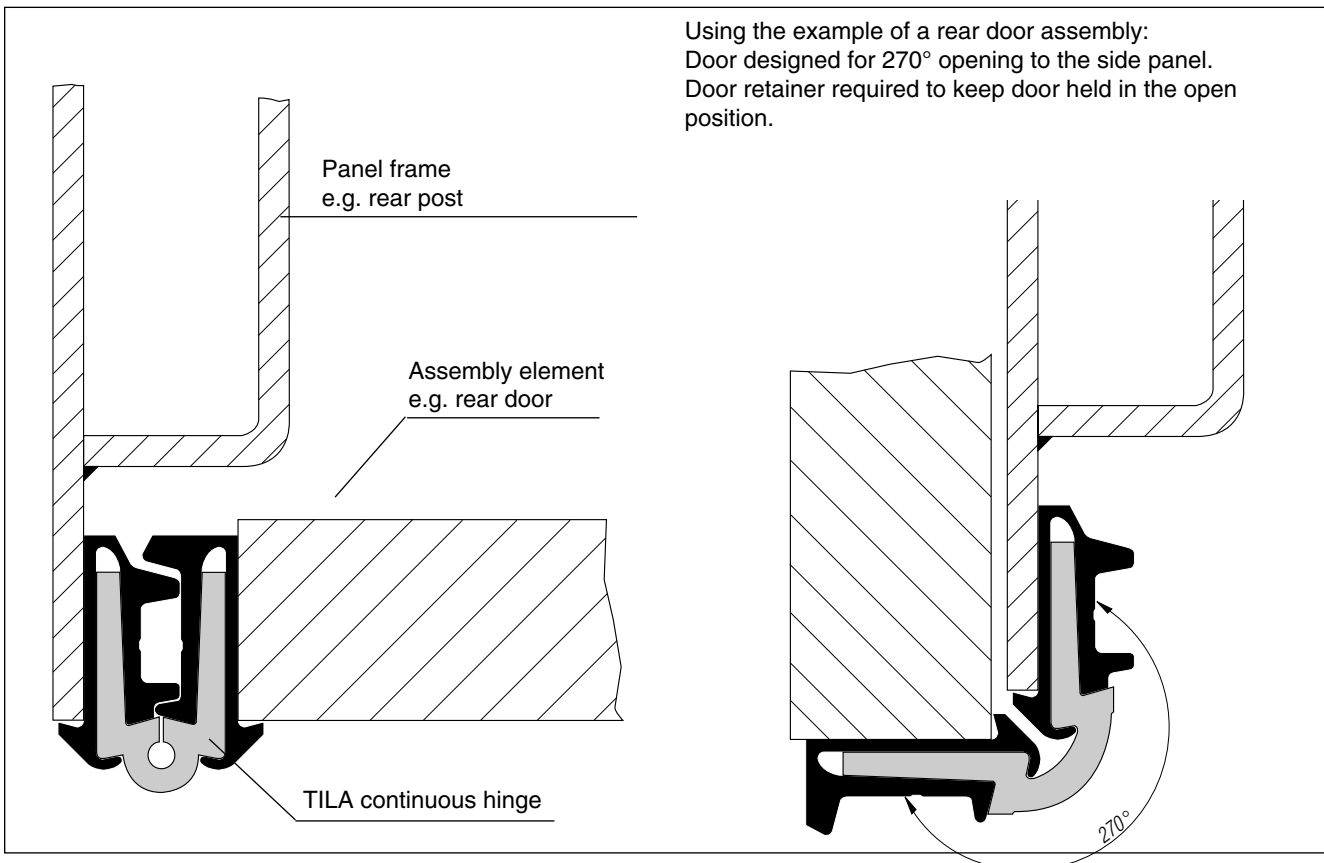

Using the example of a rear door assembly:
Door designed for 270° opening to the side panel.
Door retainer required to keep door held in the open position.